



NEW Hinged Sliding Ratchet Clamp

Lightweight, heavy duty ratchet clamp designed to improve wide diameter cable management for overhead gantry and mass transit applications. Suitable for road, railway and infrastructure, the HSRC family is easy to install, V0 rated and retrofittable using standard M6 bolts. The releasable slider allows for varying cable diameters to be managed within a single system.

Features:

- Releasable/adjustable – adding or removing cables is easy
- Vibration tested – performance even in demanding environments
- UV resistant – suitable for long term outdoor applications
- Lightweight – installer-friendly, especially operating at height
- Retrofittable – expedite installation, quicker job times
- V0 rated – tested against EN45545-2

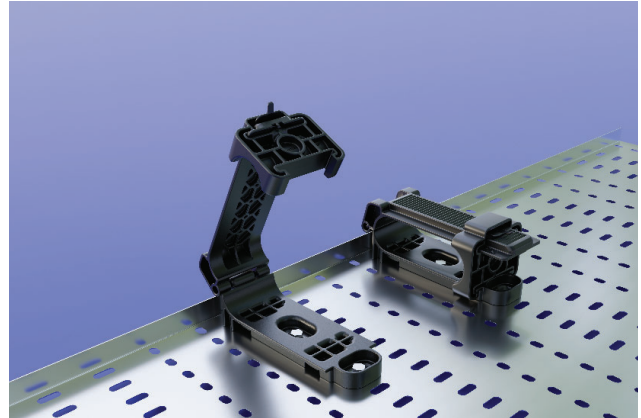

HSRC Series

Material	PA66+PA6 TS V0
Operating Temperature	-40°C to 120°C
Torque Rating	11.5Nm
Fixing Method	M6 Bolt

TYPE	Length (L)	Width (W)	Height (H)	Ø min.*	Ø max.	Colour	Box Qty	Article-No.
HSRC72	175mm	79mm	72mm	27mm	37mm	Black (BK)	40	151-04629
HSRC126	175mm	79mm	126mm	54mm	91mm	Black (BK)	20	151-04628

*Minimum single use cable.

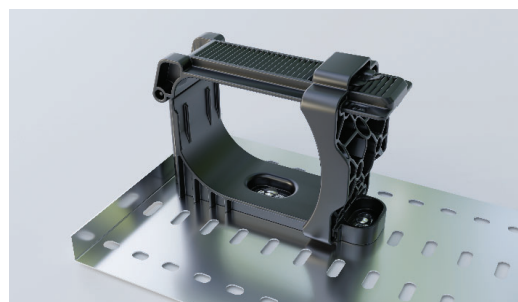
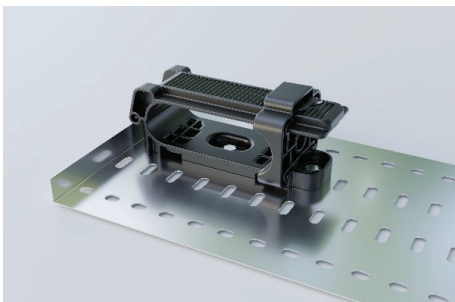

EN 45545-2