

D Series Connectors

Quick disconnect circular plastic connectors



Hypertac® Hyperboloid Technology

Smiths Interconnect offers an extensive range of superior contact technologies suitable for standard and custom solutions. Hypertac® (HYPERboloid conTACT) is the original superior performing hyperboloid contact technology designed for use in all applications and in harsh and demanding environments where high reliability and safety are critical. The inherent electrical and mechanical characteristics of the Hypertac hyperboloid contact ensures unrivalled performance in terms of reliability, number of mating cycles, low contact force and minimal contact resistance.

The contact sleeve is formed by wires, in a hyperboloid geometry, which align themselves elastically as contact lines around the pin, providing a number of linear contact paths.

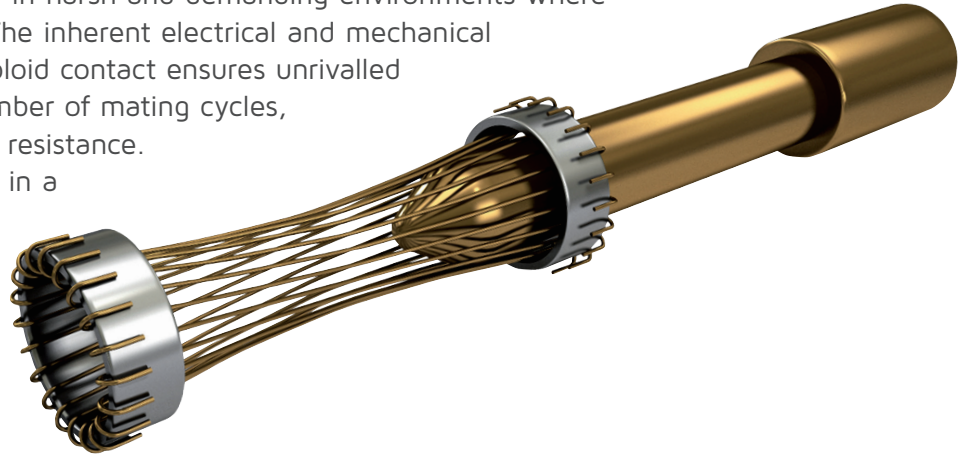

Features

Benefits

Low insertion/extraction forces

The angle of the socket wires allows tight control of the pin insertion and extraction forces. The spring wires are smoothly deflected to make line contact with the pin.

High density interconnect systems

Significant reductions in size and weight of sub-system designs. No additional hardware is required to overcome mating and unmating forces.

Long contact life

The smooth and light wiping action minimizes wear on the contact surfaces. Contacts perform up to 100,000 insertion/extraction cycles with minimal degradation in performance.

Low cost of ownership

The Hypertac contact technology will surpass most product requirements, thus eliminating the burden and cost of having to replace the connector or the entire subsystem.

Lower contact resistance

The design provides a far greater contact area and the wiping action of the wires insures a clean and polished contact surface. Our contact technology has about half the resistance of conventional contact designs.

Low power consumption

The lower contact resistance of our technology results in a lower voltage drop across the connector reducing the power consumption and heat generation within the system.

Higher current ratings

The design parameters of the contact (e.g., the number, diameter and angle of the wires) may be modified for any requirement. The number of wires can be increased so the contact area is distributed over a larger surface. Thus, the high current carried by each wire because of its intimate line contact, can be multiplied many times.

Maximum contact performance

The lower contact resistance of the Hypertac contact reduces heat build-up; therefore Hypertac contacts are able to handle far greater current in smaller contact assemblies without the detrimental effects of high temperature.

Immunity to shock & vibration

The low mass and resultant low inertia of the wires enable them to follow the most abrupt or extreme excursions of the pin without loss of contact. The contact area extends 360° around the pin and is uniform over its entire length. The 3 dimensional symmetry of the Hypertac contact design guarantees electrical continuity in all circumstances.

Reliability under harsh environments

Harsh environmental conditions require connectors that will sustain their electrical integrity even under the most demanding conditions such as shock and vibration. The Hypertac contact provides unmatched stability in demanding environments when failure is not an option.

Contents

Hypertac® Hyperboloid Technology.....	2
D series features & benefits.....	4
Dimensions:	
Standard plug & receptacle options D01 & D02.....	5
Standard plug & receptacle options D04.....	6
Panel mount receptacle, Cable mount receptacle, Plug.....	7
General specifications:	
D01 series standard.....	8
D02 series standard.....	9
D02 series (Power & Signal).....	10
D02 Series (Coax or Power & Signal).....	11
D04 Series standard.....	12
Mounting dimensions D01 & D02.....	13
How to order:	
Standard D01 & D02 series.....	14
D02 Series (Coax or Power & Signal).....	15
D04 Series standard.....	16
You may also be interested in.....	18
Product Portfolio.....	19

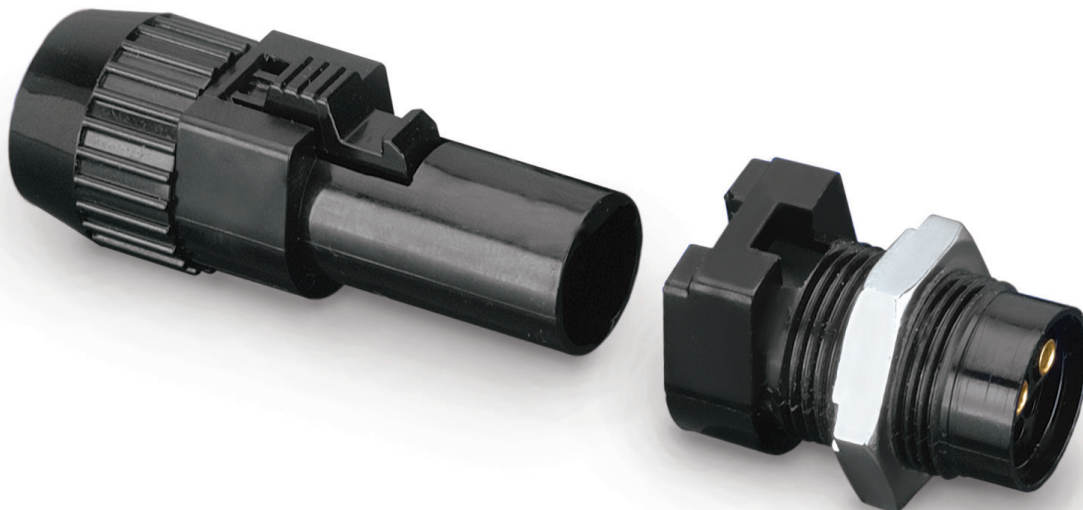

D Series



Smiths Interconnect's intuitive and durable D Series is recognized for its ease of use and high reliability. The D Series delivers industry-leading performance featuring simple push-button latching and a "D" shaped flange which makes mating orientation obvious.

There are three D Series sizes that accommodate a wide variety of applications. The D01 plug is available with up to nine Hypertac® hyperboloid contacts in less than 0.5" diameter, while the slightly larger D02 offers more extensive options, from three power to 25 signal contacts, or a mixture of power or coax and signal contacts. In addition, the D04 connector includes 82 signal contacts to provide higher density and voltages.

The D Series provides medical equipment designers with reliable connections for applications as diverse as electro-physiology catheters, patient monitors, MRIs, intravascular ultrasounds, defibrillators, infusion pumps and laboratory equipment. Polyetherimide versions are autoclavable for reusable medical device applications. D Series connectors are also used in a variety of industrial, rail and commercial applications where reliability is critical.

Cable assemblies are also offered, incorporating the D Series with overmolding, integrated electronics, metal shells for increased strength, or alternate contact configurations to meet specific customer requirements.

For a variety of applications where reliability is critical

Features & Benefits

Push-button latching feature

- Quick connect – simple one-hand mating/unmating

Available in 3 standard sizes

- D01, D02 and D04
- Standard stocked connectors offered with 3 to 82 contacts

D-shaped housings

- Visually intuitive mating

Hybrid signal, power and coaxial contact technologies available

- Design flexibility allowing multiple contact technologies within a single connector solution

Designed for critical medical applications

- Provides high reliability in a cost effective package
- Autoclavable: Versions with polyetherimide insulators can be autoclaved up to 20 times (pre-vacuum method, 4 minutes each @135°C)

Fixed and in-line receptacles available

- Easy incorporation into box and extension cable designs

Housing alignment and polarization

- Designed to prevent mismating

Custom cable assemblies available

- Complete system solutions reduce logistic and sourcing costs

Crimp contacts shipped unloaded

- Easier termination for reduced cost of ownership: crimp and poke termination eliminates the need to pre-tin, solder or shrink boot

Dimensions

Standard plug & receptacle options

For D01, D02

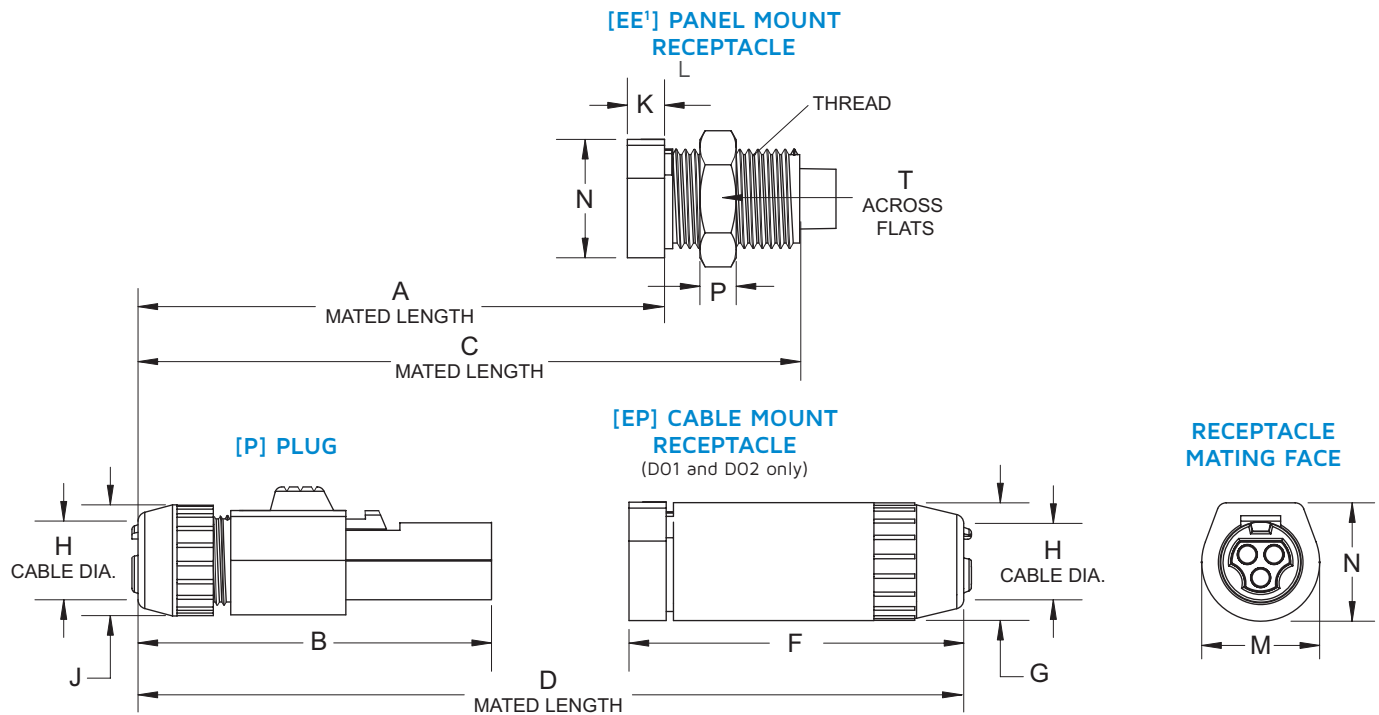

		Dimensions													
		A	B	C	D	F	G	H	J	K	L	M	N	P	T
D01		1.142 (29.00)	1.614 (41.00)	1.732 (44.00)	2.400 (61.00)	1.500 (38.00)	Ø0.512 (13.00)	Ø0.118 (3.00) Min. 0.216 (5.50) Max.	Ø0.472 (12.00)	0.161 (4.10)	M11 X 1.00 Thd.	0.512 (13.00)	0.512 (13.00)	0.157 (4.00)	0.512 (13.00)
D02		1.358 (34.50)	1.950 (49.50)	2.087 (53.00)	2.953 (75.00)	1.772 (45.00)	Ø0.709 (18.00)	Ø0.197 (5.00) Min. 0.315 (8.00) Max.	Ø0.709 (18.00)	0.276 (7.00)	M15 X 1.00 Thd.	0.669 (17.00)	0.689 (17.50)	0.153 (3.89)	0.744 (18.90)

Dimensions are in inches (mm)
All specifications are subject to change without notice

Dimensions

Standard plug & receptacle options

For D04

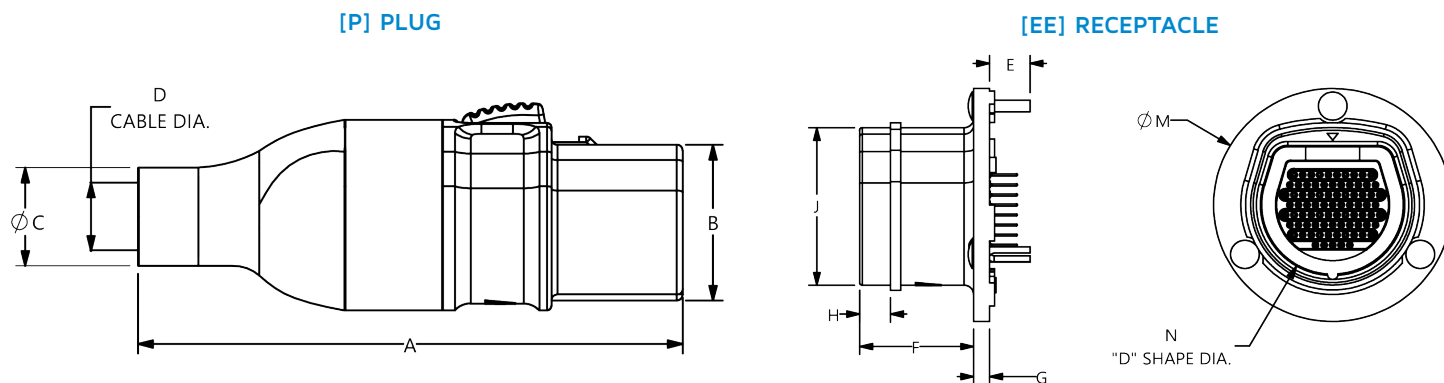

MATED CONNECTORS

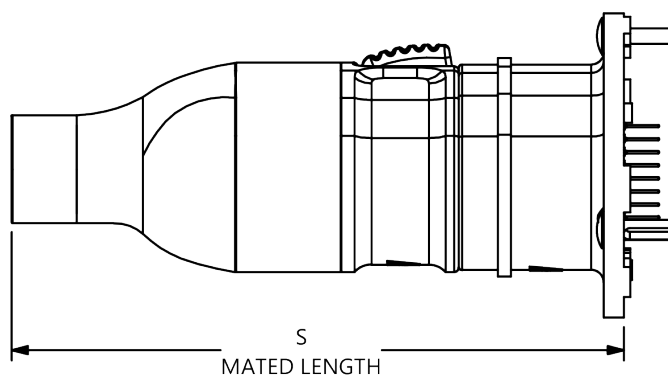

RECEPTACLE MOUNTING DIMENSIONS

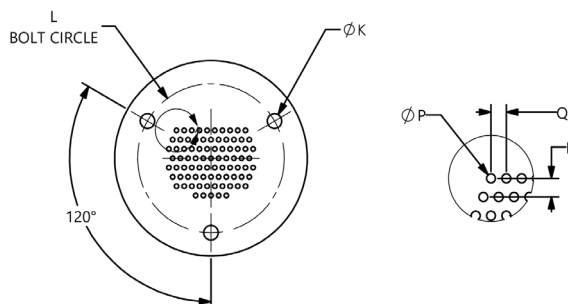

Dimensions

A	B	C	D	E	F	G	H	J	K	L	M	N	P	Q	R	S
3.560 (90.40)	1.030 (26.10)	Ø0.650 (Ø16.50)	Ø0.433 (Ø11.00)MIN Ø0.512 (Ø13.00)MAX	0.311 (7.90)	0.875 (22.24)	0.122 (3.10)	0.236 (6.00)	1.236 (31.40)	Ø0.221 (Ø5.60)	Ø1.259 (Ø32.00)	Ø1.831 (Ø46.50)	Ø1.259 (Ø32.00)	Ø0.039 (Ø0.98)	0.066 (1.67)	0.079 (2.00)	3.700 (93.90)

Dimensions are in inches (mm)

All specifications are subject to change without notice

[EE] Panel mount receptacle

D01 Shown

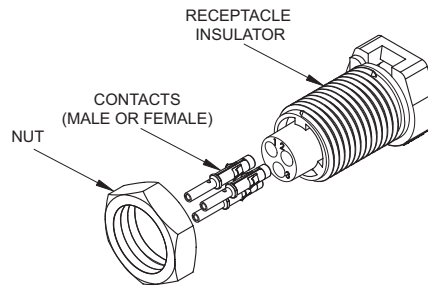

[EP] Cable mount receptacle

D01 Shown

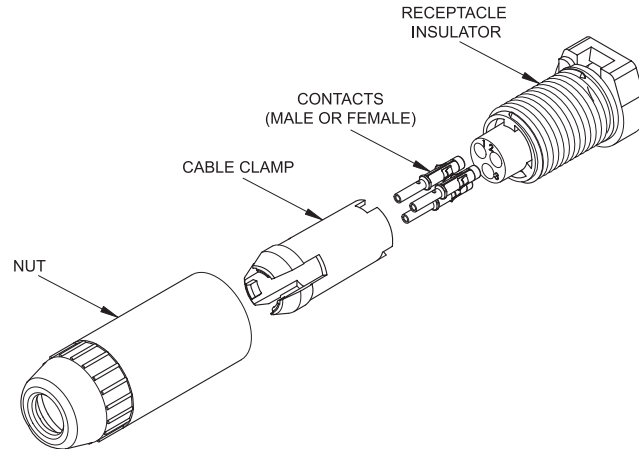

[P] Plug

D01 Shown

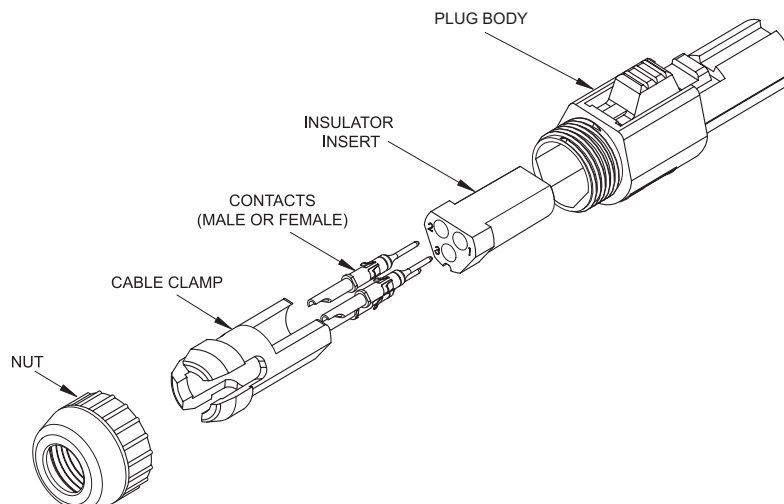

General Specifications

(Contact arrangements & technical characteristics)

D01 series

Standard

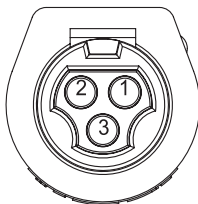

Receptacles seen from mating face

Number of Contacts	3	4	9
Contact Diameter	0.024 [0.60]		0.016 (0.40)

Terminations

Crimp (pin & socket)	22 to 26 AWG	26 to 28 AWG
Solder Cup (pin & socket)	Up to 22 AWG	Up to 26 AWG

Materials & Finishes

Insulator	Polycarbonate or Polyetherimide	Polyetherimide
Socket	Beryllium copper wires and brass body	
Pin	Brass or phosphor bronze	
Mating Surface Plating	Gold over nickel	

Electrical

Current Rating	4.0 A	1.0 A
Contact Resistance	< 5.0 mΩ	< 8.0 mΩ
Breakdown Voltage Between Contacts	2250 V min.	1000 V min.
DWV	1650 V	750 V
Insulation Resistance	> 10 ³ MΩ at 500 VDC	

Mechanical & Environmental

Contact Mating Cycle Life	Up to 100,000	
Extraction Force	0.50 to 2.00 oz. per contact	0.30 to 1.60 oz. per contact
Operating Temperature Rating	-40° to 85° C	-40° to 125° C

Accessories

Crimp Tool	AFM8 or M22520/2-01	
Positioner	K547	T1914
Extraction Tool	S/DEM1.0060	—
Insertion Tool	T1866	T2080

Dimensions are in inches (mm)

All specifications are subject to change without notice

D02 series

Standard

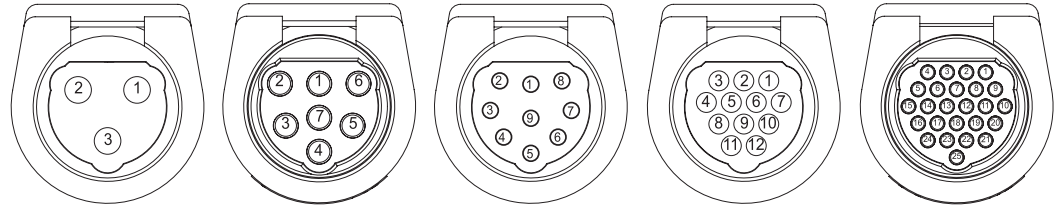

Receptacles seen from mating face

Number of Contacts	3	7	9	12	25
Contact Diameter	0.059 (1.50)	0.024 (0.60)	0.024 (0.60)	0.018 (0.50)	0.016 (0.40)

Terminations

Crimp (pin & socket)	18 to 20 AWG	22 to 26 AWG	26 to 28 AWG
Solder Cup (pin & socket)	Up to 16 AWG	Up to 22 AWG	up to 26 AWG

Materials & Finishes

Insulator	Polycarbonate or Polyetherimide	Polyetherimide
Socket	Beryllium copper wires and brass body	
Pin	Brass or phosphor bronze	
Mating Surface Plating	Gold over nickel	

Electrical

Current Rating	8.0 A	4.0 A	4.0 A	2.5 A	1.0 A
Contact Resistance	< 2.0 mΩ	< 5.0 mΩ	< 5.0 mΩ	< 8.0 mΩ	< 8.0 mΩ
Breakdown Voltage Between Contacts	2250 V min.	2000 V min.	1560 V min.	1000 V min.	1000 V min.
DWV	1650 V	1500 V	1150 V	750 V	750 V
Insulation Resistance	> 10 ³ MΩ at 500 VDC				

Mechanical & Environmental

Contact Mating Cycle Life	Up to 100,000				
Extraction Force (oz. per contact)	1.80 to 5.40	0.50 to 2.00	0.50 to 2.00	0.30 to 1.60	0.30 to 1.60
Operating Temperature Rating	-40° to 85° C				-40° to 125° C

Accessories

Crimp Tool	AF8	AFM8 or M22520/2-01			
Positioner	TP688	K623	T870	T1914	
Extraction Tool	S/DEM5.0150	S/DEM1.0060	—	—	
Insertion Tool	T1888	T1866	T1271	T2080	

Dimensions are in inches (mm)

All specifications are subject to change without notice

D02 series

Power & Signal

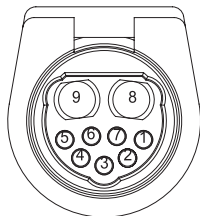

Receptacles seen from mating face

POWER

SIGNAL

Number of Contacts	2	7
Contact Diameter	0.059 (1.50)	0.018 (0.50)
Termination Style	Crimp (<i>pin & socket</i>) 16 to 20 AWG	Crimp (<i>pin & socket</i>) 22 to 26 AWG

Materials & Finishes

Insulator	Polycarbonate or Polyetherimide	
Socket	Beryllium copper wires and brass body	
Pin	Brass	
Mating Surface Plating	Gold over nickel	

Electrical

Current Rating	8.0 A	2.5 A
Contact Resistance	< 2.0 mΩ	< 8.0 mΩ
Insulation Resistance	> 10 ³ MΩ at 500 VDC	

Mechanical & Environmental

Extraction Force	1.80 to 5.40 oz. per contact	0.30 to 1.60 oz. per contact
Operating Temperature Rating	-40° to 85° C	

Accessories

Crimp Tool	AF8	AFM8
Positioner	T1164 (pin) TP688 (socket)	T870
Extraction Tool	T1124	—
Insertion Tool	T1888	T1215

Dimensions are in inches (mm)

D02 series

Coax or Power & Signal

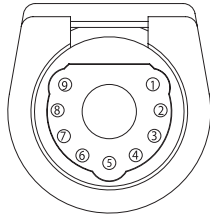

Receptacles seen from mating face

	POWER	COAX	SIGNAL
Number of Contacts	1 (either Power or Coax)		9
Contact Diameter	0.098 (2.50)	0.124 (3.15)	0.018 (0.50)

Termination Style

Crimp (pin & socket)	12 AWG	RG316 or RG316DB	22 to 26 AWG
Solder Cup (pin & socket)	—	RG405 or T-Flex 405	Up to 22 AWG

Materials & Finishes

Insulator	Polyetherimide		
Socket	Beryllium copper wires and brass body		
Pin	Brass or phosphor bronze		
Mating Surface Plating	Gold over nickel		

Electrical

Current Rating	25 A	—	2.5 A
Contact Resistance			
Discrete Contacts	< 1.5 max.	—	< 8.0 max.
Inner Contact	—	8.0 mΩ max.	—
Outer Contact	—	2.0 mΩ max.	—
Insulation Resistance	> 10 ³ MΩ at 500 VDC		

Mechanical & Environmental

Extraction Force (oz. per contact)	6.00 to 25.00	1.50 to 6.0 (3.00 average)	0.30 to 1.60 oz. per contact
Operating Temperature Rating	-40° to 125° C		

Accessories

Crimp Tool	M309	HX3 (outer) AFM8 (inner)	AFM8
Crimp Die Set	—	T1958 (outer) T2019 (outer for RG316DB)	—
Positioner	T1981	T1957 (inner)	T870
Extraction Tool	T1982	T1982	—
Insertion Tool	—	—	T1215

Dimensions are in inches (mm)

All specifications are subject to change without notice

D04 series

Standard

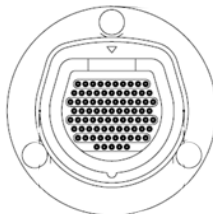

Receptacle seen from mating face

Number of Contacts	82
Contact Diameter	0.016 (0.40)
Termination Style	Crimp (pin) 26 to 28 AWG / Thru-hole PCB (socket)

Materials & Finishes

Insulator	Liquid Crystal Polymer
Socket	Beryllium copper wires and brass body
Pin	Phosphor bronze
Mating Surface Plating	Gold over nickel

Electrical

Current Rating	1.0 A
Contact Resistance	< 12 mΩ
Breakdown Voltage Between Contacts	1000 V min.
DWV	750 V
Insulation Resistance	> 10 ³ MΩ at 500 VDC

Mechanical & Environmental

Contact Mating Cycle Life	Up to 100,000
Extraction Force	0.35 to 1.60 oz. per contact
Operating Temperature Rating	-40° to 125° C

Accessories

Crimp Tool	AFM8 or M22520/2-01
Positioner	T1973
Insertion Tool	T1970

Dimensions are in inches (mm)

Mounting Dimensions

Panel cutout

For standard D01 and D02

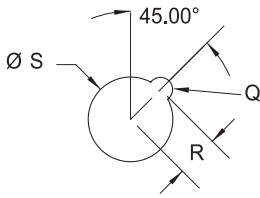

	Q	R	S
D01	Ø0.126 [3.20]	0.220 [5.60]	Ø0.441 [11.20]
D02	Ø0.10 [2.54]	0.295 [7.50]	Ø0.598 [15.19]

Dimensions are in inches (mm)

Panel cutout

For Power & Signal D02 series
(2 Power + 7 Signal Version)

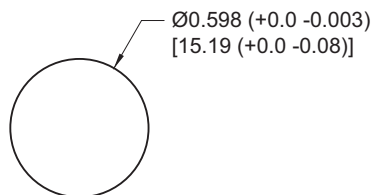

MOUNTING PLATE MATERIAL	MAX. THICKNESS
Steel	0.062 (1.60)
Other	0.094 (2.40)

Note:

1) Recommended tightening torque for panel mount receptacle for both D01 and D02 is (0.452 to 0.678 N•m).
All specifications are subject to change without notice

How To Order



1 Series	D 0 1 Series D 0 2 Series
2 Insulator	P Plug E E Receptacle panel mount E P Receptacle Cable Mount <i>(Not available for 215/705 or 503 Configurations)</i>
3 Color <i>(Fixed)</i>	B Black
4 Contact arrangement	3 0 6 D01 3 Contacts 4 0 6 D01 4 Contacts 9 0 4 D01 9 Contacts 3 1 5 D02 3 Contacts 7 0 6 D02 7 Contacts 9 0 6 D02 9 Contacts 1 2 5 D02 12 Contacts 2 5 0 4 D02 25 Contacts 2 1 5 / 7 0 5 D02 2 Power / 7 signal contacts
5 Contact gender	M Male F Female
6 Termination styles⁽¹⁾	R Crimp ⁽²⁾ S Solder cup
7 Material <i>(Omit for polycarbonate D01 306, 406; D02 315, 706, 906, 125, 2 Power / 7 Signal only)</i>	U Polyetherimide
8 Plating	T 10 µin gold (min) over nickel <i>(male contacts only)</i> T H 50 µin gold (min) over nickel <i>(male contacts only)</i> T A H 50 µin gold (min) over nickel on mating surface, gold flash over nickel on termination <i>(female contacts only)</i>

Notes:

1) Contacts shipped unassembled

2) D00 available with "R" termination only (for crimp or solder)

3) D00 panel mount receptacle with 6" pigtail leads preterminated D00EEB-0001

All specifications are subject to change without notice

How To Order

Coax or Power & Signal only



	D	0	2		B	9	0	5						U			
	1	2	3	4	5	6	7	8	9	10	11						
1 Connector series + size <i>(Fixed)</i>	D 0 2 Series																
2 Insulator	P	Plug				E	Receptacle panel mount				E	Receptacle Cable Mount					
3 Color <i>(Fixed)</i>	B Black																
4 Contact arrangement <i>(Fixed)</i>	9 0 5 9 signal contacts																
5 Signal contact gender	M	Male				F	Female										
6 Signal termination styles⁽¹⁾	R	Crimp				S	Solder cup										
7 Coaxial/power cable type	1	C	1 RG 316 <i>(crimp)</i>				1	C	2 T-FLEX 405, RG 405 <i>(solder)</i>								
8 Coax contact gender	M	Male				F	Female										
9 Coax termination styles⁽¹⁾	R	Crimp				S	Solder cup										
10 Material <i>(Fixed)</i>	U Polyetherimide <i>(black)</i>																
11 Plating	T	10 µin gold (min) over nickel <i>(male contacts only)</i>															
	T	H 50 µin gold (min) over nickel <i>(male contacts only)</i>															
	T	A H 50 µin gold (min) over nickel on mating surface, gold flash over nickel on termination <i>(female contacts only)</i>															

Note:

1) Contacts shipped unassembled

All specifications are subject to change without notice

How To Order

High Voltage



D 0 4		W	0 8 2			U	7		
1	2	3	4	5	6	7	8	9	10

1 Connector series + size <i>(Fixed)</i>	D 0 4 Series
2 Insulator	P Plug E E Receptacle panel mount
3 Color <i>(Fixed)</i>	W White
4 Contact arrangement <i>(Fixed)</i>	0 8 2 82 signal contacts
5 Signal contact gender	M Male (Plug only) F Female (Receptacle only)
6 Signal termination styles	R Crimp (Pin) X Thru-hole PCB (Socket)
7 Material <i>(Fixed)</i>	U Polyetherimide <i>(white)</i>
8 Strain relief size* <small>Cable diameter ranges</small>	7 5mm to 6.5mm
9 Color Coding*	G Light gray (Standard) D Blue R Red V Green Y Yellow B Black
10 Plating	T 10 µin gold (min) over nickel <i>(male contacts only)</i> T H 50 µin gold (min) over nickel <i>(male contacts only)</i> T A H 50 µin gold (min) over nickel on mating surface, gold flash over nickel on termination <i>(female contacts only)</i>

*Select strain relief size and color coding only for P type.

Plug connectors are shipped as unassembled kits, receptacle connectors are shipped fully assembled.

Note:

1) Contacts shipped unassembled

All specifications are subject to change without notice

Disclaimer

All of the information included in this catalogue is believed to be accurate at the time of printing. It is recommended, however, that users should independently evaluate the suitability of each product for their intended application and be sure that each product is properly installed, used and maintained to achieve desired results.

Smiths Interconnect makes no warranties as to the accuracy or completeness of the information, and disclaims any liability regarding its use.

Smiths Interconnect reserves the right to modify design and specifications, in order to improve quality, keep pace with technological development or meet specific production requirements.

No reproduction or use without express permission of editorial and pictorial content, in any manner.

You may also be interested in



Push-Pull High Density Circular Connectors

Easily keyed in 6 standard positions to prevent mismatching and available with 5 color code options
 Multiple contact technologies available
 Sealing to IP65 when mated
 UL94 flammability rated materials
 Single use disposable plugs designed to support overmolding/high volume production methods and to withstand at least 30 cycles



Modular and Mini-Modular Connectors

Mixed signal, power, coaxial, fiber optic and pneumatic modules
 Provides up to 200 amp power
 Cable to chassis and rack & panel; plastic backshell with strain relief and half turn quick disconnect jackscrew
 Float mountable for blind mating
 Configurations compliant to EN45545 standards



Edge Card Connectors

Double-ended edge card contact design (Patented technology)
 Minimum 2,500 mating cycles
 Simple push-button active latch prevents inadvertent unmating
 Tolerates standard sterilization protocols: Autoclave, EtO, Sterrad®



Product Portfolio

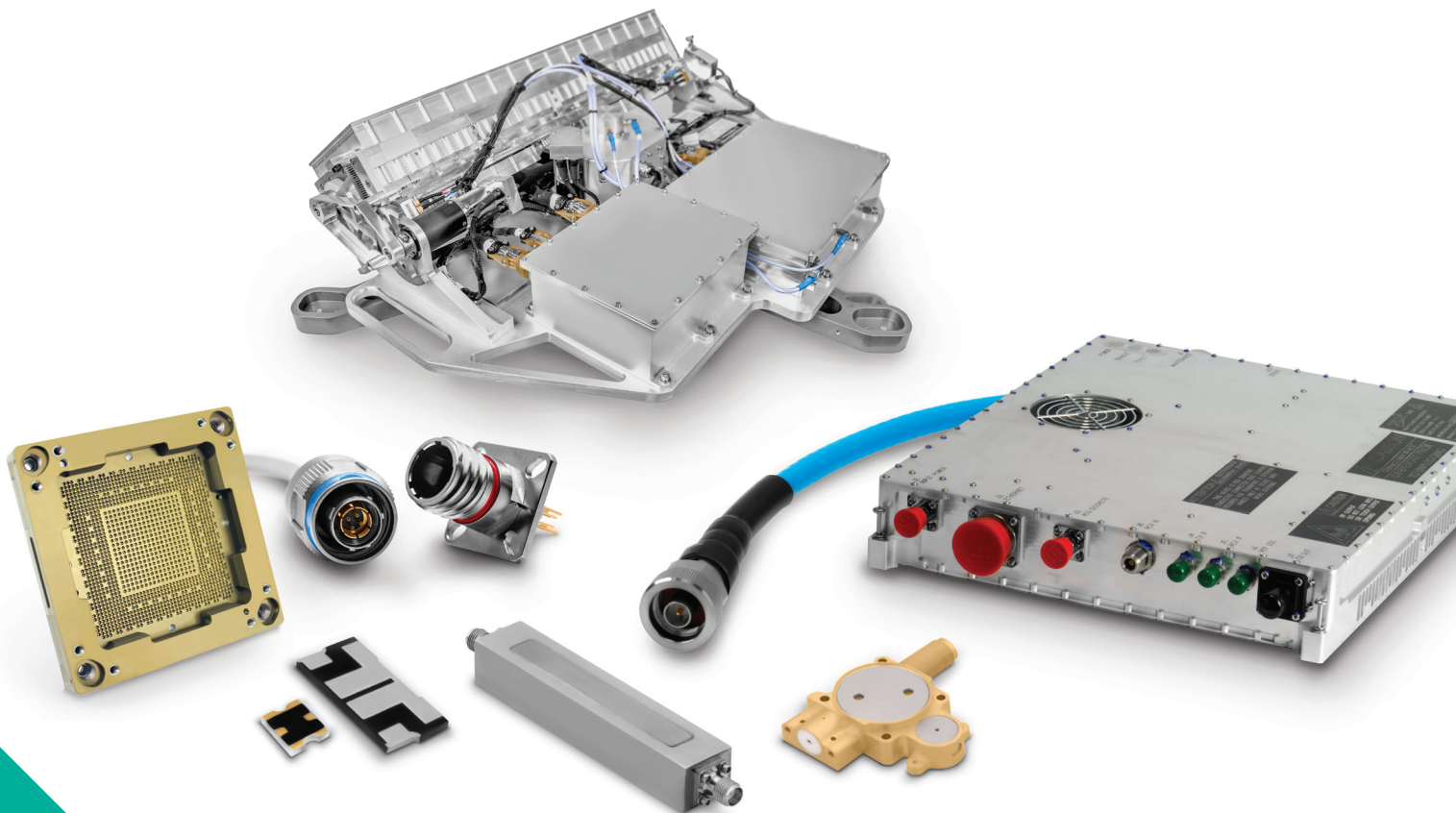

Antenna Systems

Cable Assemblies

Connector Solutions

Ferrite Components & Assemblies

RF Filter Components & Assemblies

Integrated Microwave Assemblies

Millimeter-Wave Solutions

RF Components

Test Sockets and WLCSP Probe Heads

Time & Frequency Systems

Worldwide Support

Connectors

Americas

Sales

connectors.uscsr@smithsinterconnect.com

Technical Support

connectors.ustechsupport@smithsinterconnect.com

Europe

Sales

connectors.emeacsr@smithsinterconnect.com

Technical Support

connectors.emeatechsupport@smithsinterconnect.com

Asia

Sales

asiacsr@smithsinterconnect.com

Technical Support

asiatechsupport@smithsinterconnect.com

Fibre Optics & RF Components

Americas

Sales

focom.uscsr@smithsinterconnect.com

Technical Support

focom.techsupport@smithsinterconnect.com

Europe

Sales

focom.emeacsr@smithsinterconnect.com

Technical Support

focom.techsupport@smithsinterconnect.com

Asia

Sales

focom.asiacsr@smithsinterconnect.com

Technical Support

focom.techsupport@smithsinterconnect.com

Semiconductor Test

Americas

Sales

semi.uscsr@smithsinterconnect.com

Technical Support

semi.techsupport@smithsinterconnect.com

Europe

Sales

semi.emeacsr@smithsinterconnect.com

Technical Support

semi.techsupport@smithsinterconnect.com

Asia

Sales

semi.asiacsr@smithsinterconnect.com

Technical Support

semi.techsupport@smithsinterconnect.com

RF/MW Subsystems

Americas, Europe & Asia

Sales

subsystems.csr@smithsinterconnect.com

Technical Support

subsystems.techsupport@smithsinterconnect.com

Connecting Global Markets

more > [smithsinterconnect.com](https://www.smithsinterconnect.com) | [in](#) [X](#) [v](#)