

smiths connectors

# FILTER D-SUB CONNECTORS

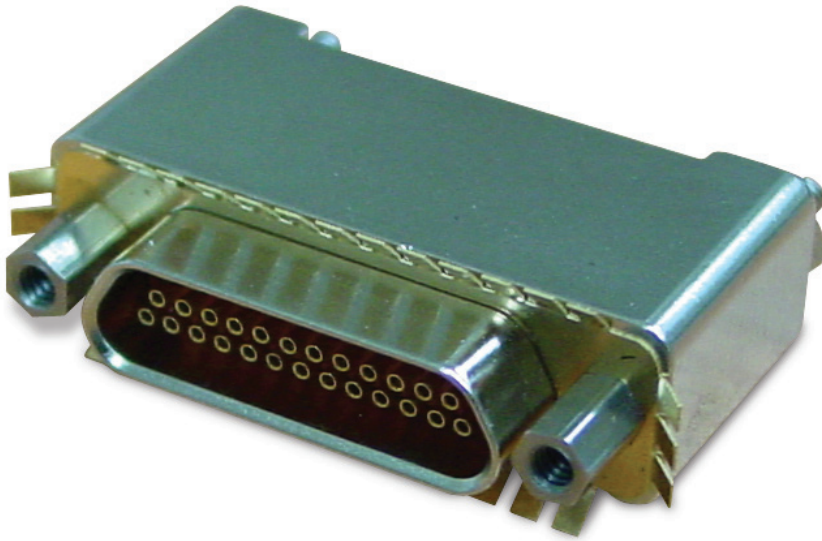

# TABLE OF CONTENTS

MIL-DTL-24308 .....	3
▶ Layouts.....	3
▶ D-Subminiature Connectors.....	4
▶ How to order.....	5
MIL-DTL-83513 .....	6
▶ Connectors and Layouts .....	7
▶ How to order.....	8
COMBO D-SUB MINIATURE .....	9
▶ High Power Plugs.....	9
▶ High Power Receptacles.....	10
▶ Electrical Characteristics.....	11
▶ Performance Data .....	14
▶ Contact Termination .....	15
▶ Solderless Filter Connectors .....	16
▶ Filter Adapters .....	17



MIL-DTL-24308 D-Subminiature filter connectors are designed to meet or exceed all applicable requirements of the military specification. These connectors are intermateable and interchangeable with the standard non-filtered connectors. Smith Connectors also offers combo D-Sub arrangements for power coaxial and signal contacts mixed arrangements. These layouts include 5W5, 8W8, 17W2, 9W1 and 24W7.

MATERIALS AND FINISHES	
Shell	Aluminum alloy/Steel/Composite
Insulator	High grade plastic/epoxy
Contacts	Copper alloy, gold plate
Grommet & Seal	Silicon base elastomer
Capacitor	Barium Titanate
Inductor	Ferrite bead

### Insert Arrangements

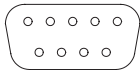

9 #20

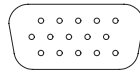

15 #22

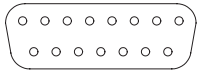

15 #20

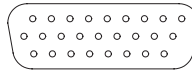

26 #22

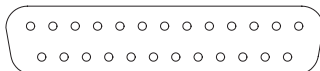

25 #20

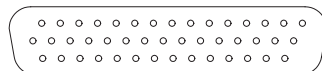

44 #22

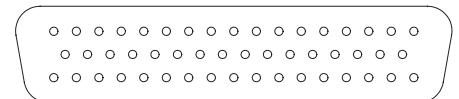

50 #20

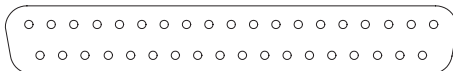

37 #20

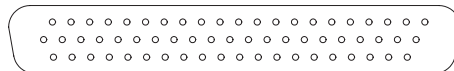

62 #22

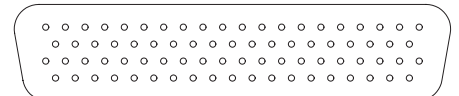

78 #22

Consult Factory for Combo D-Sub Arrangements.

Smith Connectors provides specialty, enhanced performance connectors and cable assemblies and as such does not currently offer circular, rack and panel, or D-subminiature connectors that are listed on military standard Qualified Products Lists (QPL) per applicable detail specification sheets. Smith Connectors' connectors are fully intermateable with applicable QPL products and meet the applicable requirements of all military standards listed in this catalog.

▶ STRAIGHT D-SUBMINIATURE

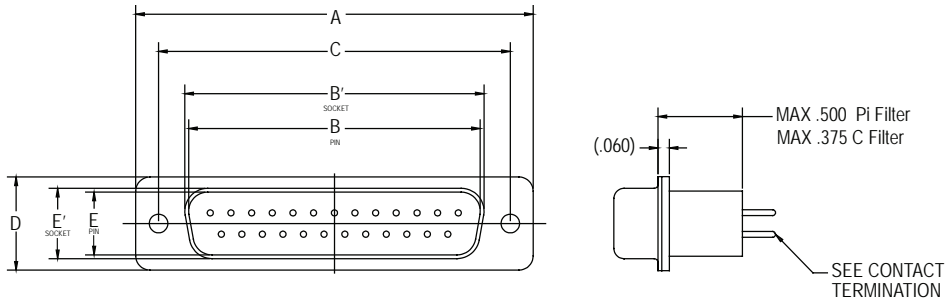

▶ RIGHT ANGLE D-SUBMINIATURE

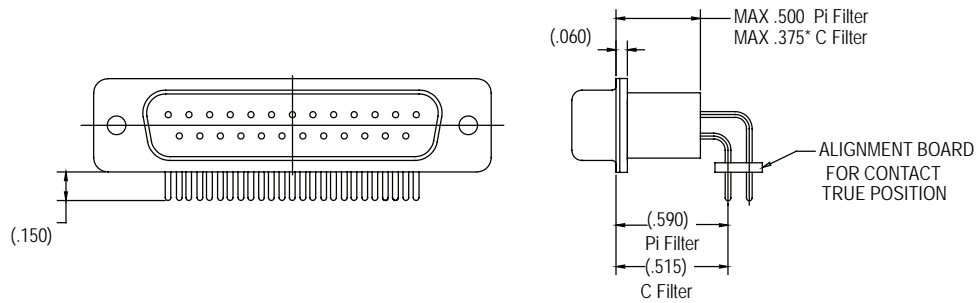

▶ OPTIONAL HARDWARE

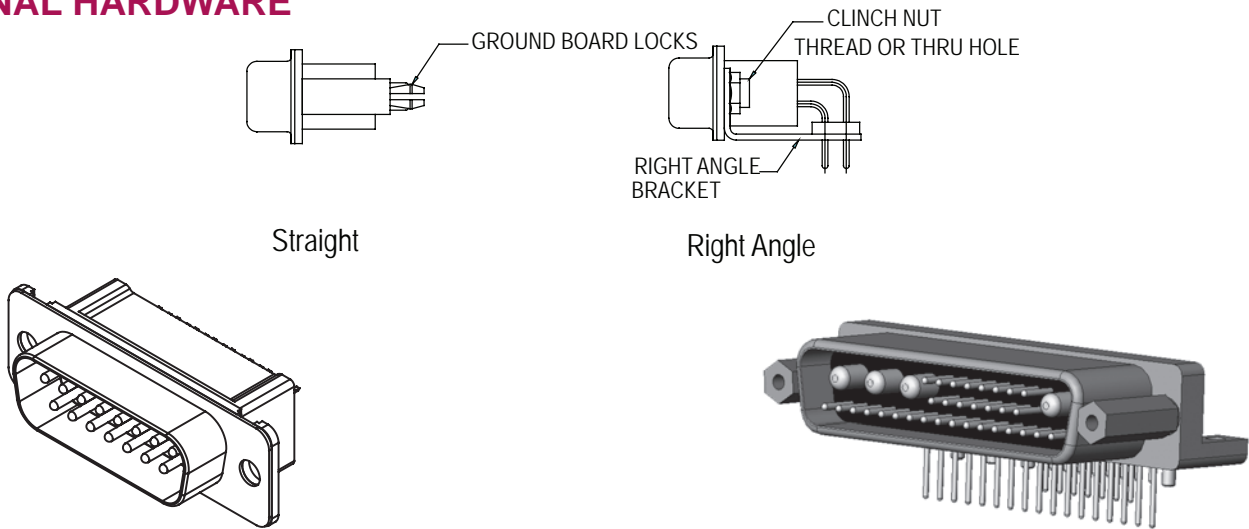

Shell Size	Standard Layout Size 20	A ± 0.015	B (Pin) ± 0.005	B' (Socket) ± 0.005	C Basic	D ± 0.010	E (Pin) ± 0.005	E' (Socket) ± 0.005
E	9 Contact	1.213	.667	.642	.984	.494	.330	.310
A	15 Contact	1.541	.995	.970	1.312	.494	.330	.310
B	25 Contact	2.088	1.535	1.150	1.852	.494	.330	.310
C	37 Contact	2.729	2.183	2.158	2.500	.494	.330	.310
D	50 Contact	2.635	2.063	2.063	2.406	.605	.437	.422

# HOW TO ORDER

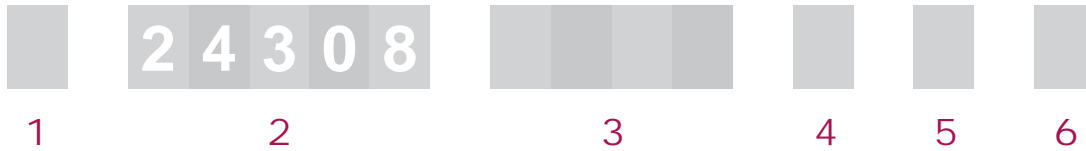

## 1 ▸ FILTER TYPE

**P**i, **L**, **C**

## 2 ▸ PREFIX

## 3 ▸ CONTACT ARRANGEMENT

LOW DENSITY **9**, **15**, **25**, **37**, **50**

HIGH DENSITY **15HD**, **26HD**, **44HD**, **62HD**, **78HD**

## 4 ▸ CONTACT TYPE

**P** PIN

**S** SOCKET

## 5 ▸ CONTACT TERMINATION

**S** SOLDER CUP

**P** PC TAIL

**C** CRIMP

## 6 ▸ PLATING

**C** CADMIUM (YELLOW CHROMATE)

**N** ELECTROLESS NICKEL



MIL-DTL-83513 Micro-D filter connectors are designed to meet or exceed all applicable requirements of the military specification. These connectors are intermateable and interchangeable with the standard non-filtered connectors. Unique configurations are also available with customized shells and EMI ground springs.

MATERIALS AND FINISHES

Shell	Aluminum alloy
Insulator	High grade plastic/epoxy
Contacts	Copper alloy, gold plate
Grommet & Seal	Silicon base elastomer
Capacitor	Barium Titanate
Inductor	Ferrite bead

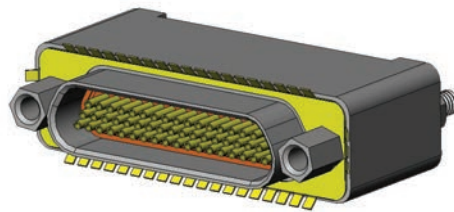
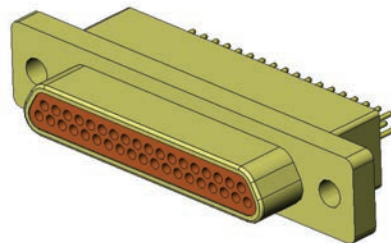
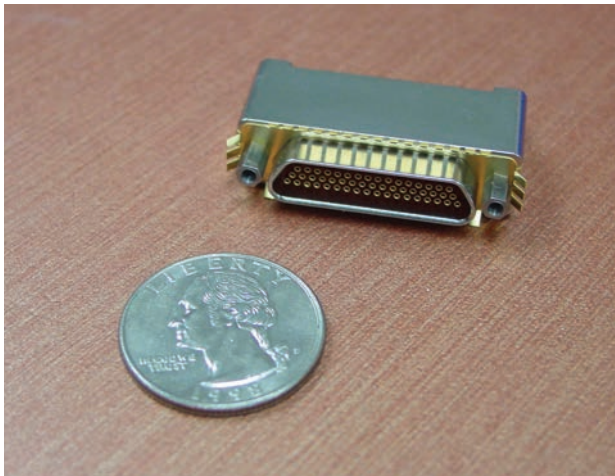

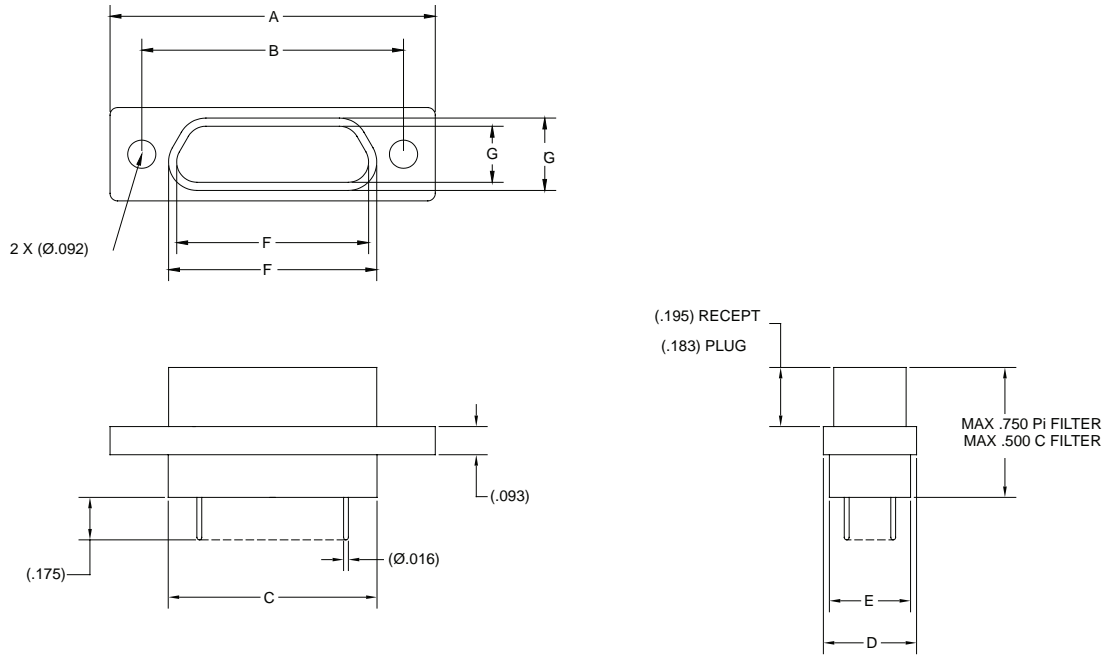

Cavity	A ± .010	B Basic	C + .010 -.018	D ± .010	E Max	F Basic Recept	F' Basic Plug	G Basic Recept	G' Basic Plug
9	.775	.565	.390	.298	.270	.3342	.338	.1852	.1848
15	.925	.715	.540	.298	.270	.4842	.4838	.1852	.1848
21	1.075	.865	.690	.298	.270	.6342	.6338	.1852	.1848
25	1.175	.956	.790	.298	.270	.7342	.7338	.1852	.1848
31	1.325	1.115	.940	.298	.270	.8842	.8838	.1852	.1848
37	1.475	1.265	1.090	.298	.270	1.0342	1.0338	.1852	.1848
51	1.425	1.215	1.040	.341	.310	.9842	.9838	.2282	.2278
100	2.160	1.800	1.432	.384	.360	1.3842	1.3838	.2712	.2708

### Insert Arrangements

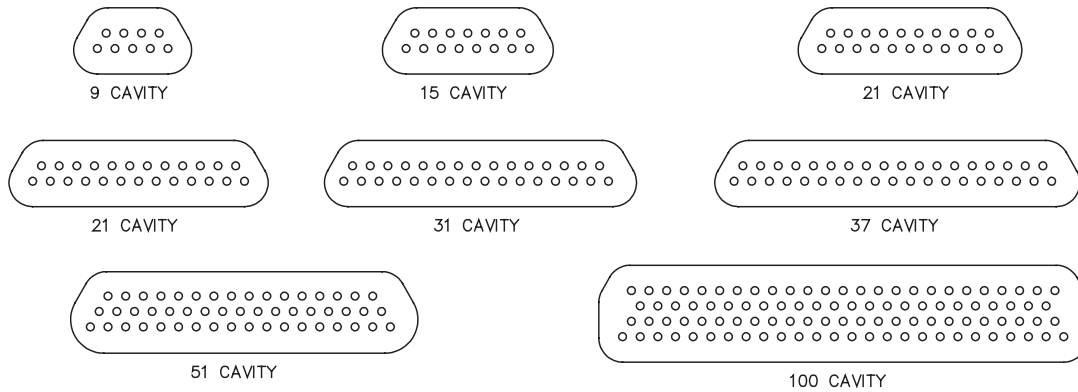

\* Consult Factory For Additional or Custom Layouts

# HOW TO ORDER



**1** ▶ FILTER TYPE

**Pi**, **L**, **C**

**2** ▶ PREFIX

**3** ▶ CONTACT ARRANGEMENT

**9**, **15**, **21**, **25**, **31**, **37**, **51**, **100**

**4** ▶ CONTACT TYPE

**P** PIN

**S** SOCKET

**5** ▶ CONTACT TERMINATION

**S** SOLDER CUP

**P** PC TAIL

**F** FLYING LEADS

**R** RIGHT ANGLE\*

**6** ▶ PLATING

**C** CADMIUM (YELLOW CHROMATE)

**N** ELECTROLESS NICKEL

\* Consult factory for alternate plating options.  
Consult factory for footprint dimensions.

Smith Connectors provides specialty, enhanced performance connectors and cable assemblies and as such does not currently offer circular, rack and panel, or D-subminiature connectors that are listed on military standard Qualified Products Lists (QPL) per applicable detail specification sheets. Smith Connectors' connectors are fully intermateable with applicable QPL products and meet the applicable requirements of all military standards listed in this catalog.





Combo D-Sub 3W3/3WK3 Filtered Power Connectors

Smith Connectors offers a complete line of high powered EMI filtered D-Sub connectors including the single row size #8 power contacts (3W3, 3WK3, etc.). Our ceramic planar capacitors can easily achieve up to 47 nF per line on this series. The planar capacitor provides excellent attenuation as well as meeting the Bellcore requirements for 1000 VDC Dielectric Withstanding Voltage. The materials used in the construction meet the UL flammability requirements of 94V-0. Smith Connectors' filtered D-Sub connectors are intermateable with standard non-filter D-Sub connectors.

This series is available in PC tail, solder cup and solderless press-fit terminations into standard plated-thru holes. Smith Connectors also offers combo D-Sub arrangements for power coaxial and signal contacts mixed arrangements including layouts 5W5, 8W8, 17W2, 9W1 and 24W7.

## PC Tail

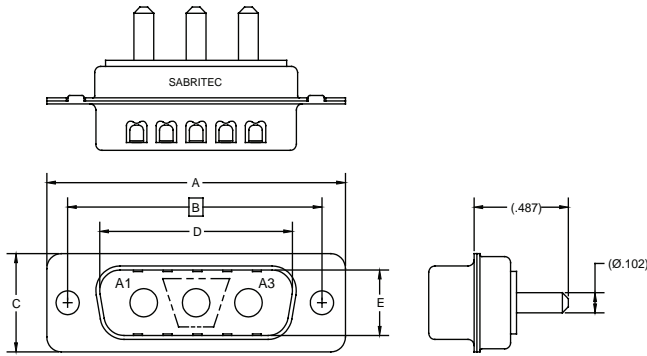

## Solder Cup

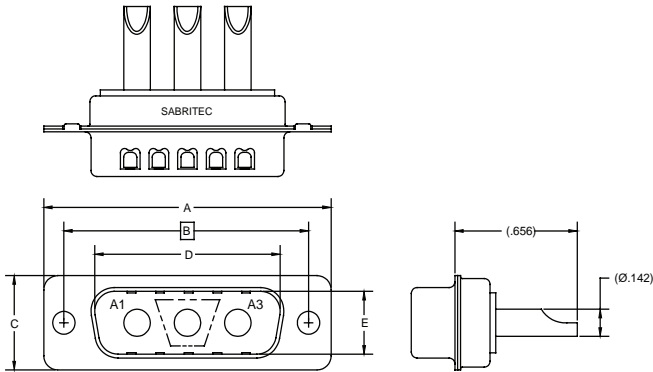

## Press-Fit

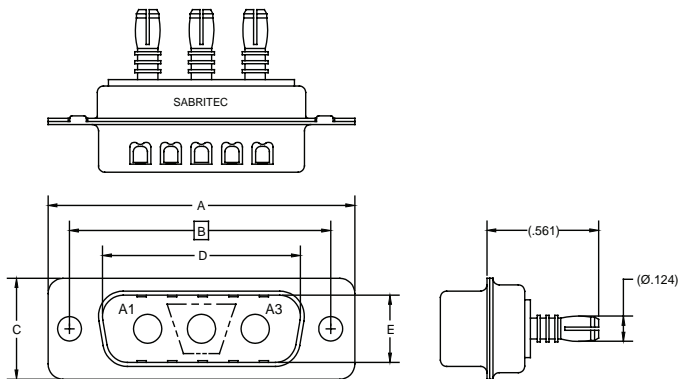

## D-Sub High Power Plugs

PART NUMBER	EMI FILTER		VOLTAGE RATING
	CAP VALUE	LAYOUT	
<a href="#">310031-1000</a>	1 NF	3W3	400 VDC
<a href="#">310032-1001</a>	1 NF	3WK3	400 VDC
<a href="#">310031-1002</a>	5 NF	3W3	400 VDC
<a href="#">310032-1003</a>	5 NF	3WK3	400 VDC
<a href="#">310031-1004</a>	47 NF	3W3	400 VDC
<a href="#">310032-1005</a>	47 nF	3WK3	400 VDC

PART NUMBER	EMI FILTER		VOLTAGE RATING
	CAP VALUE	LAYOUT	
<a href="#">310031-2000</a>	1 NF	3W3	400 VDC
<a href="#">310032-2001</a>	1 NF	3WK3	400 VDC
<a href="#">310031-2002</a>	5 NF	3W3	400 VDC
<a href="#">310032-2003</a>	5 NF	3WK3	400 VDC
<a href="#">310031-1004</a>	47 NF	3W3	400 VDC
<a href="#">310032-2005</a>	47 nF	3WK3	400 VDC

PART NUMBER	EMI FILTER		VOLTAGE RATING
	CAP VALUE	LAYOUT	
<a href="#">310031-4000</a>	1 NF	3W3	400 VDC
<a href="#">310032-4001</a>	1 NF	3WK3	400 VDC
<a href="#">310031-4002</a>	5 NF	3W3	400 VDC
<a href="#">310032-4003</a>	5 NF	3WK3	400 VDC
<a href="#">310031-4004</a>	47 NF	3W3	400 VDC
<a href="#">310032-4005</a>	47 nF	3WK3	400 VDC

Dimensions	A	B	C	D	E	F	G
	+ .010	Basic	+ .010	+ .004	+ .004	+ .004	+ .004
	1.541	1.312	0.494	0.995	0.329	0.970	0.310

► D-SUB HIGH POWER RECEPTACLES

Solder Cup

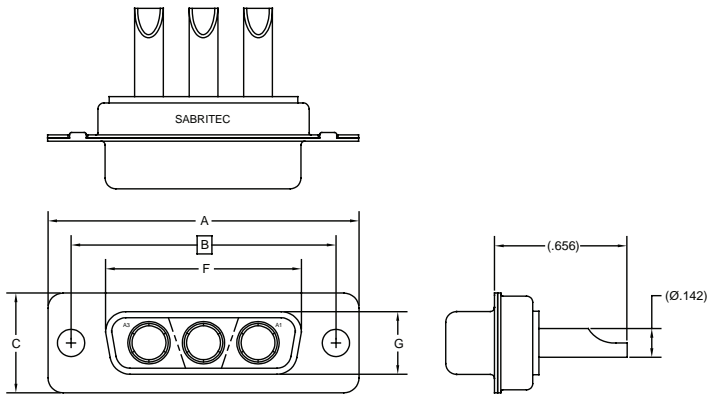

PART NUMBER	EMI FILTER		VOLTAGE RATING
	CAP VALUE	LAYOUT	
310031-3000	1 nF	3W3	400 VDC
310032-3001	1 nF	3WK3	400 VDC
310031-3002	5 nF	3W3	400 VDC
310032-3003	5 nF	3WK3	400 VDC
310031-3004	47 nF	3W3	400 VDC
310032-3005	47 nF	3WK3	400 VDC

Dimensions	A +.010	B Basic	C +.010	D +.004	E +.004	F +.004	G +.004
	1.541	1.312	0.494	0.995	0.329	0.970	0.310

Insertion Loss Curves

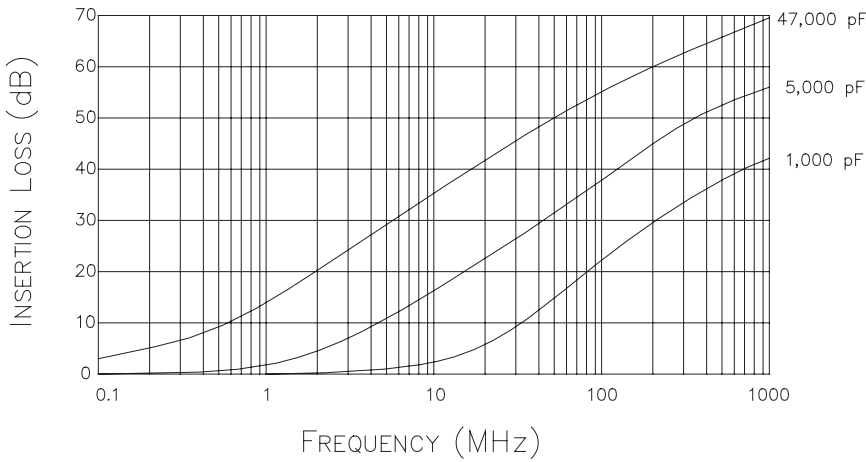

“C” Filter Schematic

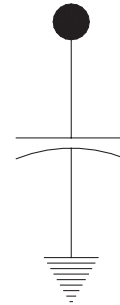

INSERTION LOSS TABLE

Frequency (MHz)	C1 (1 nF)	C5 (5 nF)	C47 (47 nF)
1	0.1	1.4	15
10	4	16	34
100	22	36	52
1000	42	56	68

ELECTRICAL CHARACTERISTICS

Operating Temperature	-55°C to +125°C
Voltage	1,000 VDC DWV 400 VDC Working
DC Current Rating	30 Amps max per contact
Surge Voltage	1,000 Volts, 1.2 x 50µ's Waveform (12 ohms) 1,000 Volts, 8 x 20µ's Waveform (2 ohms)
Insulation Resistance	5,000 Mega ohms @ 400 VDC
Capacitance	1 nF, 5 nF, 47 nF, (± 20%)
International Standard for EMC	Meets or exceeds EN 61000-4-5 IEC 1000-4-5

MATERIALS AND FINISHES

Shell	Tin plated steel
Insulator	Thermoplastic (UL 94V-Ø rated)
Contacts	Copper Alloy, gold plate per ASTM-B488 over nickel plate per QQ-N-290
Filter Array	Monolithic capacitor, X7R material

Terminations  
PC Tail  
Solder Cup  
Press Fit

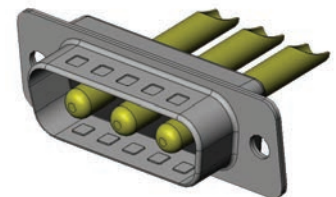

## ▶ ELECTRICAL CHARACTERISTICS - 'PI' SECTION

FILTER DESCRIPTION	P200	P100	P76	P38	P20	P10	P8	P4	P2	P1
Operating Temperature Range	-55°C to + 125°C									
Voltage Rating	100 VDC					200 VDC-120 Vrms 400 Hz				
Current Rating DC	15 amps size 16/7.5 amps size 20/5 amps size 22									
Insulation Resistance	5000 megohms min. @100 VDC									
Current Rating R.F.	3.0 amps max.									
DWV Sea Level w/ 50 micro-amps max. charge/discharge	250 VDC					500 VDC				

## ▶ 'PI' SECTION CURVES

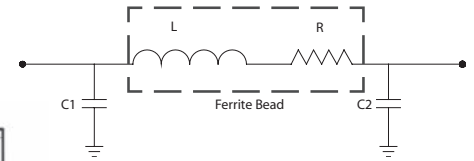
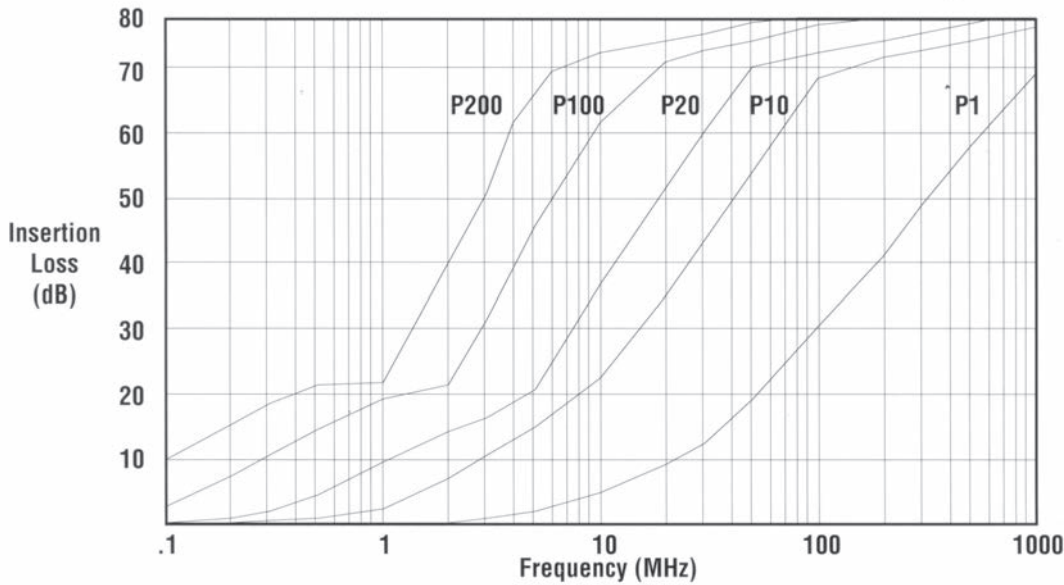

## ▶ INSERTION LOSS TABLE

FILTER DESCRIPTION	SEE NOTES	P200	P100	P76	P38	P20	P10	P8	P4	P2	P1
Capacitance in Nanofarads @ 1Khz., 1VRMS		160	80	60	30	16	8	6.4	3.2	1.6	.8
		240	120	91	46	24	12	9.2	4.8	2.4	1.2
Minimum No Attenuation loss @ 25°	Freq Mhz										
	.1	8	4.1	3	1	.3	.1	-	-	-	-
	1.0	22.2	19.6	18.2	13.3	8.2	3.9	2.9	.9	.2	-
	2	32.8	21.7	19.7	16.8	12.7	8	6.6	2.9	1	.3
	10	73.5	61	57	44.4	31.5	20.6	18.3	12.8	8.1	4.0
	100	85+	85+	85+	85+	78	65.8	61.9	49.6	37.3	25.6
500-1k	85+	85+	85+	85+	85+	85+	80	75	64	52	

Notes:  
 1. P200 & P100 Capacitance Values for Size 20 Contact Arrangement & Larger  
 2. No Load Minimum Attenuation Values per MIL-STD-220  
 3. Capacitance in Nanofarads (Nominal Value)  
 4. Consult Factory for Higher Voltages & Capacitance Values

▶ ELECTRICAL CHARACTERISTICS - 'L' SECTION

FILTER DESCRIPTION	L200	L100	L76	L38	L20	L10	L8	L4	L2	L1
Operating Temperature Range	-55°C to + 125°C									
Voltage Rating	100 VDC					200 VDC-120 Vrms 400 Hz				
Current Rating DC	15 amps size 16/7.5 amps size 20/5 amps size 22									
Insulation Resistance	5000 megohms min. @100 VDC									
Current Rating R.F.	3.0 amps max.									
DVV Sea Level w/ 50 micro-amps max. charge/discharge	250 VDC					500 VDC				

▶ 'L' SECTION CURVES

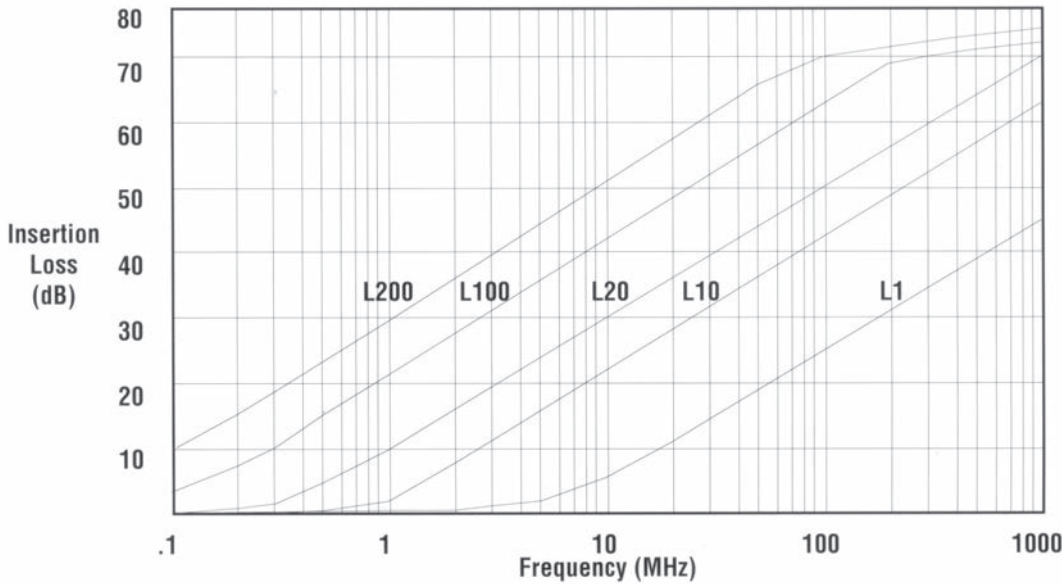
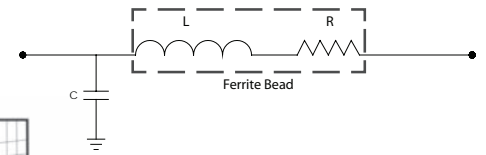

▶ INSERTION LOSS TABLE

FILTER DESCRIPTION	SEE NOTES	L200	L100	L76	L38	L20	L10	L8	L4	L2	L1
Capacitance in Nanofarads @ 1Khz, 1VRMS		160	80	60	30	16	8	6.4	3.2	1.6	.8
		240	120	91	46	24	12	9.2	4.8	2.4	1.2
Minimum No Attenuation loss @ 25°	Freq Mhz										
	.1	8.6	4.1	3	1	.3	.1	-	-	-	-
	1.0	28	22	20.1	14.2	8.6	4	3	.9	.2	-
	2	34.3	28.3	26.3	20.3	14.4	8.8	7.2	3.1	1	-
	10	49	43	41.1	35	29	23	21.1	15.1	9.5	4.8
	100	69.9	63.9	62	55.9	49.9	43.9	42	35.9	29.9	23.9
500-1k	83.7	77.7	75.8	69.7	63.7	57.7	55.8	49.7	43.7	37.7	

Notes:  
 1. L200, L100 & L76 Capacitance Values for Size 20 Contact Arrangement & Larger  
 2. No Load Minimum Attenuation Values per MIL-STD-220  
 3. Capacitance in Nanofarads (Nominal Value)  
 4. Consult Factory for Higher Voltages & Capacitance Values

## ▶ ELECTRICAL CHARACTERISTICS - 'C' SECTION

FILTER DESCRIPTION	C200	C100	C76	C38	C20	C10	C8	C4	C2	C1
Operating Temperature Range	-55°C to + 125°C									
Voltage Rating	100 VDC					200 VDC-120 Vrms 400 Hz				
Current Rating DC	15 amps size 16/7.5 amps size 20/5 amps size 22									
Insulation Resistance	5000 megohms min. @100 VDC									
Current Rating R.F.	3.0 amps max.									
DWV Sea Level w/ 50 micro-amps max. charge/discharge	250 VDC					500 VDC				

## ▶ 'C' SECTION CURVES

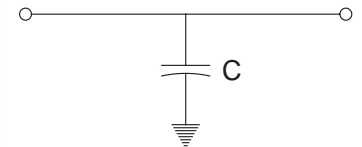
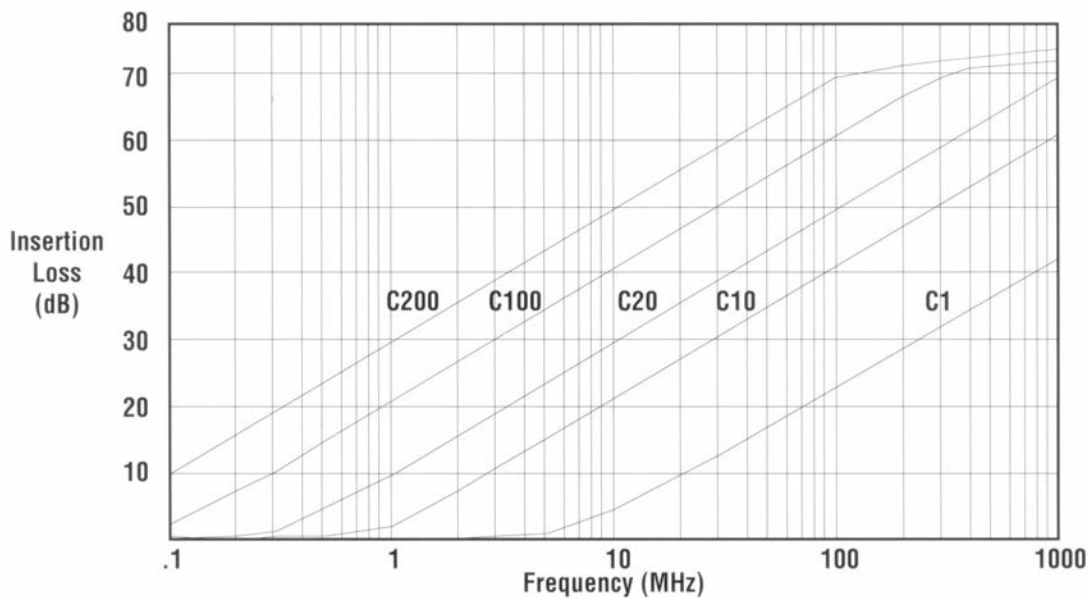

## ▶ INSERTION LOSS TABLE

FILTER DESCRIPTION	SEE NOTES	C200	C100	C76	C38	C20	C10	C8	C4	C2	C1
Capacitance in Nanofarads @ 1Khz., 1VRMS		160	80	60	30	16	8	6.4	3.2	1.6	.8
		240	120	91	46	24	12	9.2	4.8	2.4	1.2
Minimum No Attenuation loss @ 25°	Freq Mhz										
	.1	8.6	4.1	3	1	.3	.1	-	-	-	-
	1.0	28	22	20.1	14.2	8.6	4.1	3	1	.3	.1
	2	34	28	26.1	20.1	14.2	8.6	7	3	1	.3
	10	48	42	40	34	28	22	20.1	14.2	8.6	4.1
	100	68	62	60	54	48	42	40	34	28	22
500-1k	82	76	74	68	62	56	54	48	42	36	

- Notes:
1. C200, C100 & C76 Capacitance Values for Size 20 Contact Arrangement & Larger
  2. No Load Minimum Attenuation Values per MIL-STD-220
  3. Capacitance in Nanofarads (Nominal Value)
  4. Consult Factory for Higher Voltages & Capacitance Values

Smith Connectors connectors conform to the applicable military specifications and standards for materials, finishes and mechanical form, fit, and function. Filter connectors are fully intermateable and interchangeable in most instances with standard non-filtered QPL MIL-SPEC connectors.



MATERIALS AND FINISHES	
Shell & Jam Nut	Aluminum Alloy Electroless Nickel per MIL-C-26074
Pin Contacts	Brass per ASTM B16 Gold Plate per MIL-G-45204
Socket & Contacts	Copper Alloy Gold Plate per MIL-G-45204
Insulators	High Grade Plastic/Epoxy
Seal & Grommet	Silicon Base Elastomer

PRODUCTION AUTOMATION TEST SYSTEM MEASUREMENTS			
	Range	Accuracy	Notes
Capacitance	1 pF-1µf	0.2% + 0.1 pf	1
DF	0.00001-10	1%	2
Inductance	100 nH-10KH	0.2%+10 nH	1
IR	1 K Ohm - 5 T Ohm	1%	3,4,5
DWV	10 pA-100 mA	1%+10 pA	3,4,6
VR	10 mV-100V	0.2% + 10 mV	7
Ground & Contact Resistance	0.1 mV-1V	0.1%+0.1 mV	7

- Notes:**
1. Frequency = 20 Hz to 1 MHz
  2. Dissipation factor
  3. With 5-500 volts applied
  4. Measures each pin to all other pins grounded to shell
  5. Insulation resistance
  6. Dielectric withstanding voltage
  7. Isource = 1nA-1A

### Performance Data

Smith Connectors' Filter Connectors meet or exceed the applicable requirements of the following specifications:

- MIL-DTL-38999      MIL-C-26482
- MIL-DTL-83723      MIL-DTL-26500
- MIL-DTL-24308      MIL-DTL-83723
- MIL-DTL-83513      MIL-C-81511
- MIL-DTL-83527      ARINC 600
- ARINC 404 (MIL-C-81659)

Smith Connectors connectors can meet qualification requirements of MIL-DTL-38999, MIL-C-26482, ARINC 404 (MIL-C-81659), and ARINC 600. Smith Connectors can perform most test requirements in-house. This includes both electrical and mechanical testing for qualification, engineering evaluation and final acceptance. All products are available for space grade applications.

All specifications subject to change without notice.

Smith Connectors provides specialty, enhanced performance connectors and cable assemblies and as such does not currently offer circular, rack and panel, or D-subminiature connectors that are listed on military standard Qualified Products Lists (QPL) per applicable detail specification sheets. Smith Connectors' connectors are fully intermateable with applicable QPL products and meet the applicable requirements of all military standards listed in this catalog.

PC TAIL

SOLDER CUP

COMPLIANT PRESS-FIT  
(SOLDERLESS)

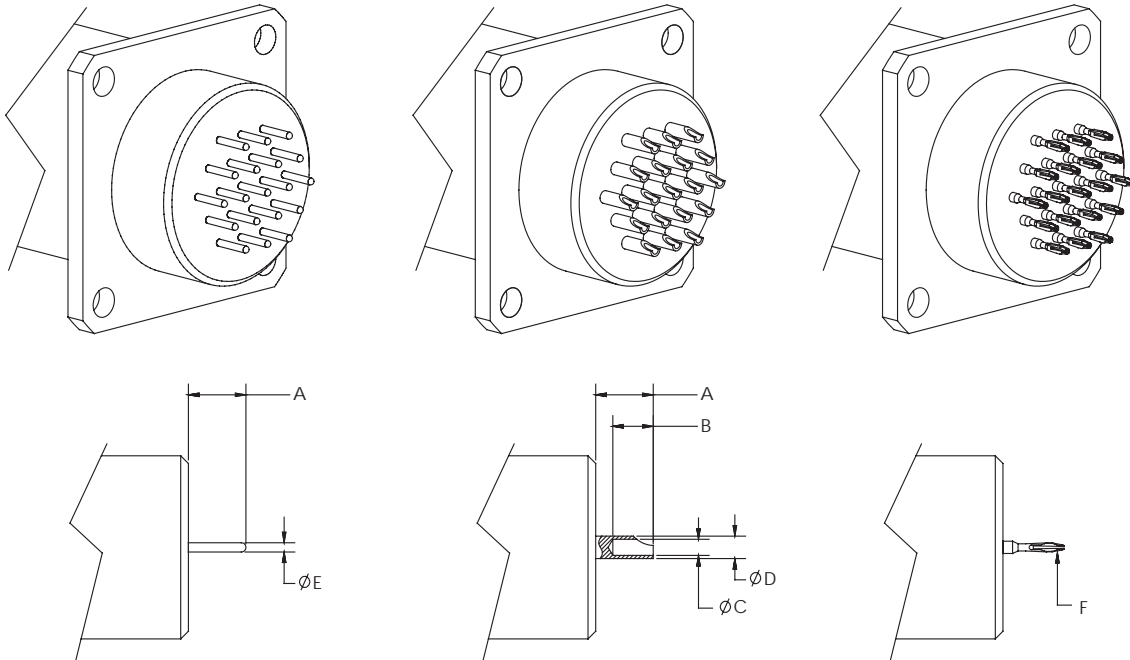

DIMENSIONS						
Contact Size	A +.025	B	C	D	E +.003	F
22	0.175	.125 .094	.040 .035	.055 .051	.020	PCB Finished Hole 0.026 + .002
20		.156 .125	.048 .042	.088 .061	.030	Consult factory for alternate size
16		.172 .141	.082 .069	.103 .097	.050	
12		.120 .112	.142 .136	.065		

Crimp / Removable\*

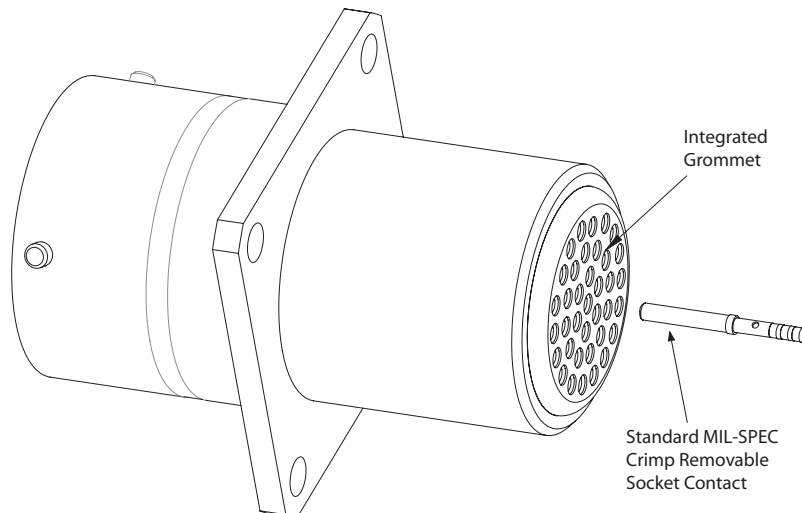

\* Add 0.700" to overall length for crimp removable connector with integrated grommet.

Smith Connectors offers filtered connectors that are capable of providing exceptional low pass filtering and effective insertion loss without the use of soldered components.

Smith Connectors has qualified the solderless filter connector design to the applicable requirements listed in MIL-DTL-38999. For the qualification test report summary, please visit the technical notes section of our website.

Solderless filter connectors contain a specially designed contact clip to make the connection from the signal/power contact to the capacitor array. An EMI ground spring provides a low resistance path between the capacitor array and connector shell. These connectors meet the same stringent electrical and mechanical requirements of soldered type filter connectors. A uniquely designed seal allows for water wash immersion of the connector in the unmated condition.

**BENEFITS OF SOLDERLESS FILTER TECHNOLOGY**

- ▶ RoHS Compliant
- ▶ No Solder design (not potted)
- ▶ Reworkable filter module assembly
- ▶ Modular construction
- ▶ High temperature lead free solder tolerant
- ▶ Qualification data available upon request

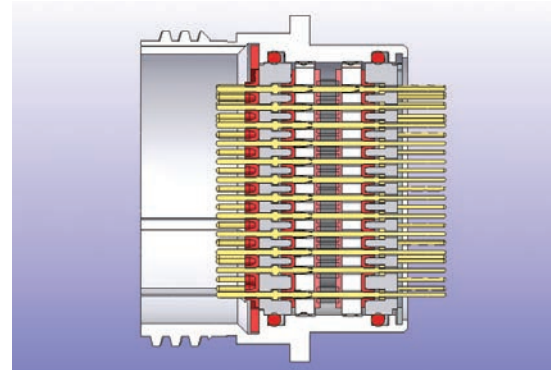

**Solderless Filter Assembly**

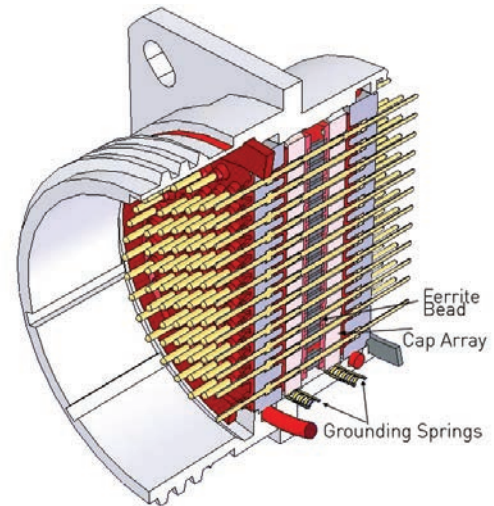

**Solder Filter Assembly**

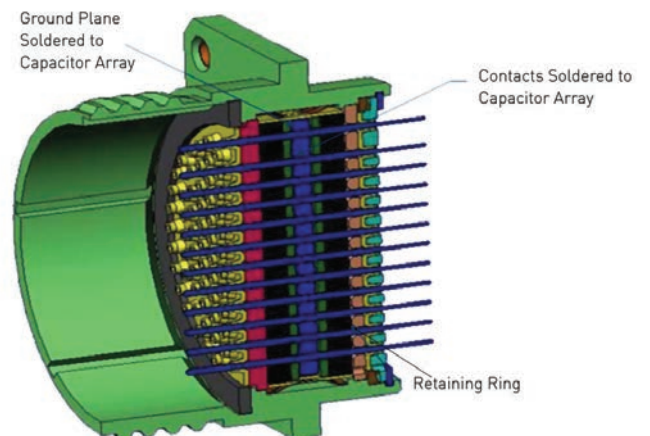

MATERIALS AND FINISHES	
Connector Shell	Aluminum alloy/Steel/Composite
Insulator	High grade plastic/epoxy
Contacts	Copper alloy, gold plate
Grommet & Seal	Silicon base elastomer
Jam Nut (if used)	Aluminum alloy
Capacitor	Barium Titanate
Inductor	Ferrite bead





Non-filter applications can easily be upgraded to EMI/Transient protection without modification to the system with Smith Connectors' In-Line Filter Adapters. Filter adapters provide the system designer great flexibility in situations where the filtering or system requirements are subject to change. The adapters are designed to be installed between the existing plug and receptacle without having to re-wire or disassemble the system. Both in-line cable and bulkhead/panel mount versions are available. Adapters can be built for any connector series including MIL-DTL-38999, MIL-C-26482, MIL-DTL-83723, MIL-DTL-24308, MIL-DTL-83513, ARINC 404, and ARINC 600. Consult the factory for more information.

## MIL-DTL-38999 Series I Adapter

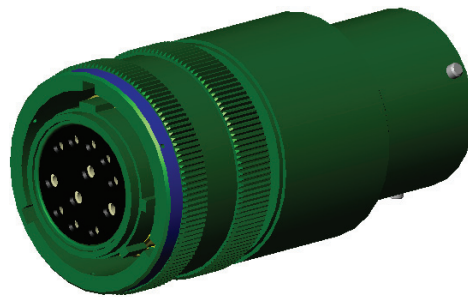

## MIL-DTL-38999 Series III Adapter



## MIL-DTL-24308 D-Subminiature Adapter

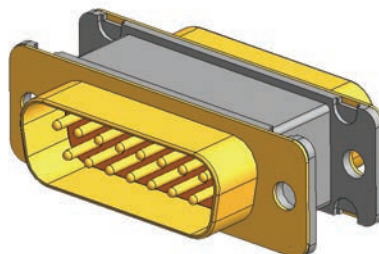



# SMITHS CONNECTORS GLOBAL SUPPORT

## AMERICAS

[info.us@smithsconnectors.com](mailto:info.us@smithsconnectors.com)

### Costa Mesa, CA

1.714.371.1100

### Hudson, MA

1.978.568.0451

### Kansas City, KS

1.913.342.5544

## EUROPE

### France

33.2.32969176

[info.fr@smithsconnectors.com](mailto:info.fr@smithsconnectors.com)

### Germany

49.991.250.120

[info.de@smithsconnectors.com](mailto:info.de@smithsconnectors.com)

### Italy

39.010.60361

[info.it@smithsconnectors.com](mailto:info.it@smithsconnectors.com)

### United Kingdom

44.208.236.2400

[info.uk@smithsconnectors.com](mailto:info.uk@smithsconnectors.com)

## ASIA

[asiainfo@smithsconnectors.com](mailto:asiainfo@smithsconnectors.com)

### Shanghai, China

86.21.3318.4650

### Suzhou, China

86.512.6273.1188

### Singapore

65.6846.1655

visit us at | [smithsconnectors.com](http://smithsconnectors.com) |     