

# MHD / MDD / MDP Connectors Series

PCB High Density Connectors

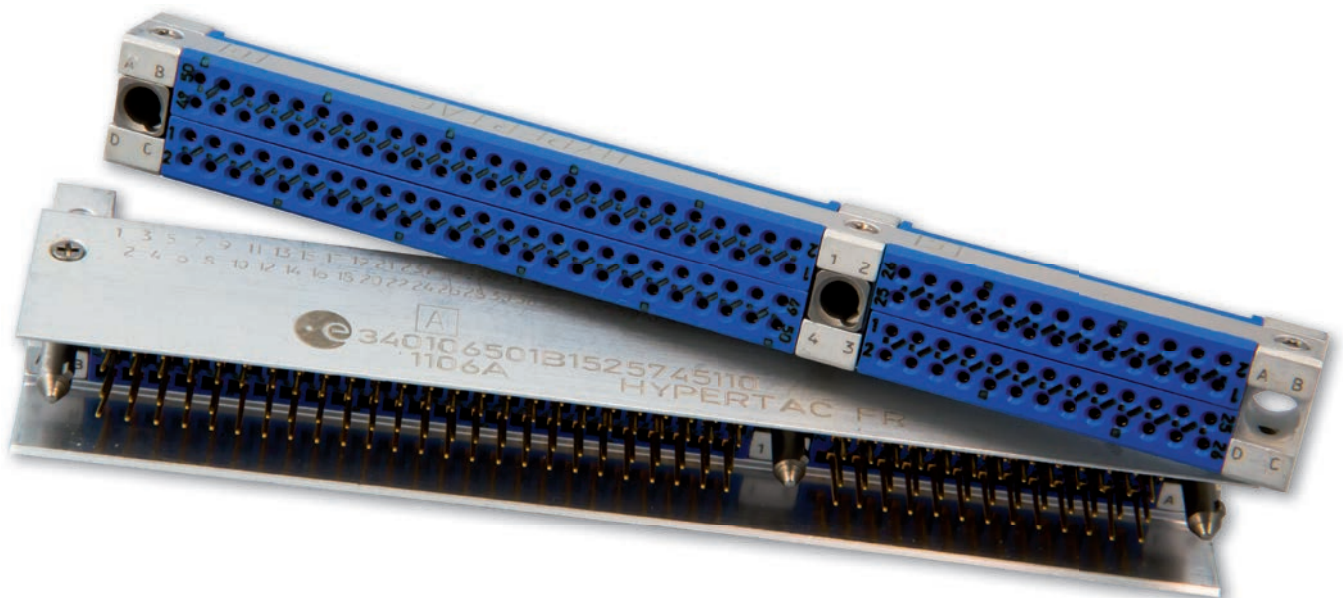

# Hypertac® Hyperboloid Technology

Smiths Interconnect offers an extensive range of superior contact technologies suitable for standard and custom solutions. Hypertac® (HYPERboloid conTACT) is the original superior performing hyperboloid contact technology designed for use in all applications and in harsh and demanding environments where high reliability and safety are critical. The inherent electrical and mechanical characteristics of the Hypertac hyperboloid contact ensures unrivalled performance in terms of reliability, number of mating cycles, low contact force and minimal contact resistance.

The shape of the contact sleeve is formed by hyperbolically arranged contact wires, which align themselves elastically as contact lines around the pin, providing a number of linear contact paths.

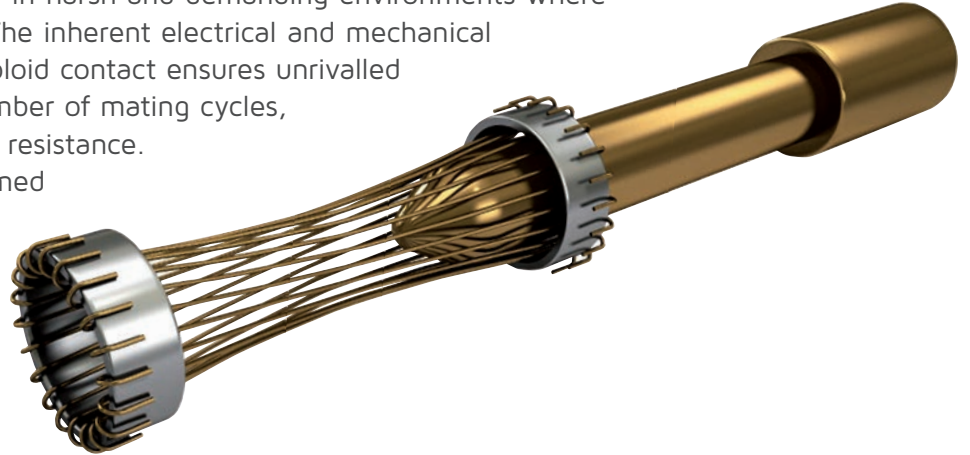

## Features

## Benefits

### Low insertion/extraction forces

The angle of the socket wires allows tight control of the pin insertion and extraction forces. The spring wires are smoothly deflected to make line contact with the pin.

### High density interconnect systems

Significant reductions in size and weight of sub-system designs. No additional hardware is required to overcome mating and unmating forces.

### Long contact life

The smooth and light wiping action minimizes wear on the contact surfaces. Contacts perform up to 100,000 insertion/extraction cycles with minimal degradation in performance.

### Low cost of ownership

The Hypertac contact technology will surpass most product requirements, thus eliminating the burden and cost of having to replace the connector or the entire subsystem.

### Lower contact resistance

The design provides a far greater contact area and the wiping action of the wires insures a clean and polished contact surface. Our contact technology has about half the resistance of conventional contact designs.

### Low power consumption

The lower contact resistance of our technology results in a lower voltage drop across the connector reducing the power consumption and heat generation within the system.

### Higher current ratings

The design parameters of the contact (e.g., the number, diameter and angle of the wires) may be modified for any requirement. The number of wires can be increased so the contact area is distributed over a larger surface. Thus, the high current carried by each wire because of its intimate line contact, can be multiplied many times.

### Maximum contact performance

The lower contact resistance of the Hypertac contact reduces heat build-up; therefore Hypertac contacts are able to handle far greater current in smaller contact assemblies without the detrimental effects of high temperature.

### Immunity to shock & vibration

The low mass and resultant low inertia of the wires enable them to follow the most abrupt or extreme excursions of the pin without loss of contact. The contact area extends 360° around the pin and is uniform over its entire length. The 3 dimensional symmetry of the Hypertac contact design guarantees electrical continuity in all circumstances.

### Reliability under harsh environments

Harsh environmental conditions require connectors that will sustain their electrical integrity even under the most demanding conditions such as shock and vibration. The Hypertac contact provides unmatched stability in demanding environments when failure is not an option.

# Contents

## MHD Series

Technical characteristics .....	2
How to order.....	3
Modules configuration.....	4
Standard plugging stages.....	5
Termination styles.....	6
Connector dimensions .....	7
Guiding devices .....	13
Contact board preparation details .....	14
Power and high frequency contacts .....	18

## MDD Series

Technical characteristics .....	19
How to order.....	20
Modules configuration.....	21
Standard plugging stages.....	22
Termination styles.....	23
Connector dimensions .....	24
Guiding devices .....	25
Contact board preparation details .....	26

## MDP Series

Technical characteristics .....	27
How to order.....	28
Connector dimensions .....	29
Guide and termination styles .....	30
Contact board preparation details .....	31

# Technical Characteristics

## Materials & Platings

Insulator	Diallyl Phthalate UL94V0
Frame	Aluminium Alloy
Contact	Copper Alloy
Guide	Brass + Ni plating or Stainless Steel
Contact plating	Ni + Au

## Environmental

Temperature range	- 55° C to +125° C
Safety of contact from extraction	Statical 2 mm / 0.079" Dynamical 1.80 mm / 0.071"
Mating cycles	5000
Withdrawal forces	≤ 0.5 N
Special contacts	According to NFC 93569

## Electrical

Contact resistance	Signal ≤ 12 mΩ Power ≤ 2 mΩ
Current rating	Signal 3 A Power 15 A
Insulation	>10 <sup>4</sup> MΩ
Voltage rating	200 V
Proof voltage	800 V
Contact diameter	Signal 0.50 mm Power 2.00 mm
Impedance	Coaxial 50 Ω

# How To Order



Code ESA

3401-065 01B



Code HYPERTAC

MHD



1

2

3

4

5

<b>1 Series</b>	
<b>2 Arrangement</b>	<p> <span>Ⓢ</span> 052   <span>Ⓢ</span> 152   <span>Ⓢ</span> 252   <span>Ⓢ</span> 352   5HA   1HB   6XA  <span>Ⓢ</span> 100   <span>Ⓢ</span> 200   <span>Ⓢ</span> 300   <span>Ⓢ</span> 400   2XA   7XB   3HB         </p>
<b>3 Part - Polarity Plating</b>	<p> <span>13</span>   <span>Ⓢ</span> 55 Male Plug Standard plating   <span>22</span>   <span>Ⓢ</span> 44 Female Receptacle Standard plating  <span>17</span>   <span>Ⓢ</span> 57 Male Plug Pretinned   <span>26</span>   <span>Ⓢ</span> 46 Female Receptacle Pretinned         </p>
<b>4 Termination Styles</b>	<p> <span>Ⓢ</span> 10 90° termination, PCB thickness 1.60   <span>Ⓢ</span> 11<sup>1)</sup> 90° termination, PCB thickness 2.40  <span>Ⓢ</span> 12<sup>2)</sup> 90° termination, PCB thickness 3.20   <span>Ⓢ</span> 30 Straight termination, PCB thickness 2.40  <span>Ⓢ</span> 31 Straight termination, PCB thickness 3.20   <span>41</span> SMT<sup>3)</sup> - PCB thickness 1.60  <span>42</span> SMT<sup>3)</sup> - PCB thickness 3.20   <span>Ⓢ</span> 43 SMT<sup>3)</sup> - PCB thickness 2.40  <span>44</span> SMT<sup>3)</sup> - Uncentered PCB thickness 3.80   <span>Ⓢ</span> 45 SMT<sup>3)</sup> - Uncentered PCB thickness 1.60  <span>Ⓢ</span> 47 SMT<sup>3)</sup> - Uncentered PCB thickness 2.40   <span>Ⓢ</span> 91 Female / male saver<sup>4)</sup> </p>
<b>5 Guide Styles</b>	<p> <span>Ⓢ</span> 110 Male polarised, transverse mount, standard plug   <span>Ⓢ</span> 111 Male polarised, vertical mount  <span>Ⓢ</span> 121 Female polarised, vertical mount   <span>122</span> Female polarised, vertical mount  <span>Ⓢ</span> 124 Female polarised, transverse mount   <span>125</span> Male unpolarised, transverse mount  <span>126</span> Female unpolarised, vertical mount   <span>130</span> Female polarised, vertical mount  <span>131</span> Female polarised, vertical mount   <span>133</span> Female all polarised, transverse mount  <span>Ⓢ</span> 134 Female polarised, transverse mount   <span>190</span> Female power or mass contact, vertical mount  <span>191</span> Male power or mass contact, transverse mount   <span>Ⓢ</span> 201 ¼ turn, free connector         </p>

1) Available for receptacle connector

2) Available for plug connector

3) Surface Mount Termination

4) Consult us - PCB thickness is in mm

# Modules Configuration

## Single Arrangements

## Receptacle Mating Side Views

## Mixed Arrangements

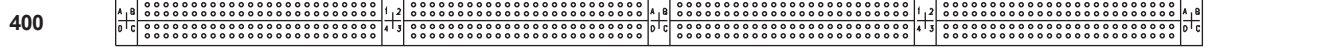
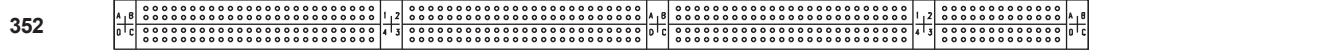
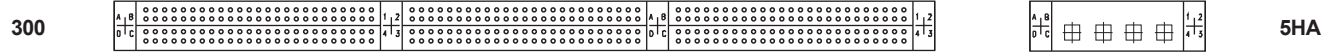
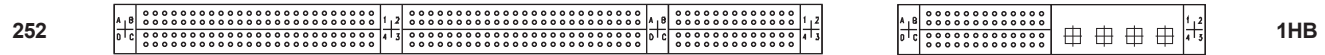
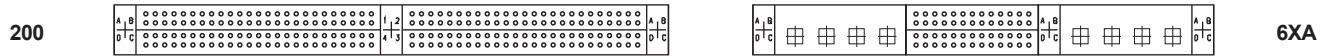
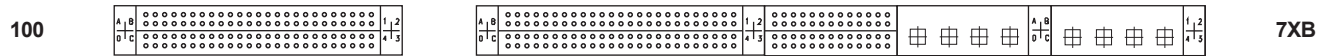
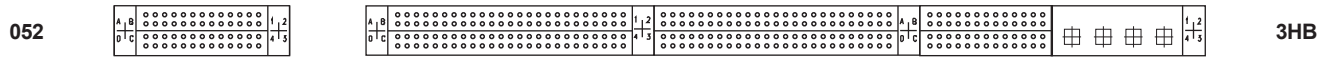

26 ways module

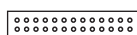

50 ways module

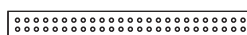

4 ways module  
(special contacts)

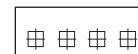

Space which can receive:  
2x50 ways module  
or  
2x26 ways module  
1x4 ways module  
or  
2x4 ways module

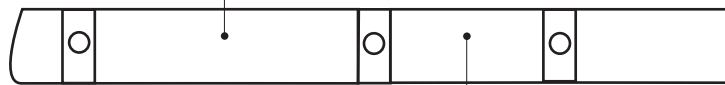

Space which can receive:  
2x26 ways module  
or  
1x4 ways module

# Standard Plugging Stages

## Misalignment

### Longitudinal

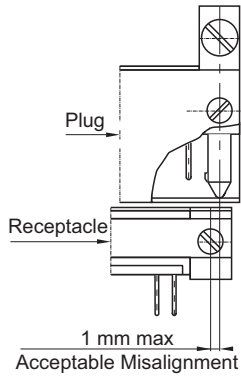

### Lateral

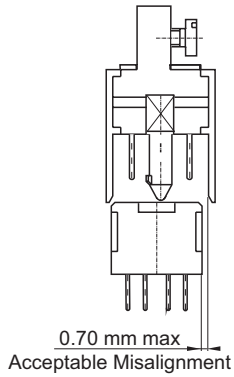

## Gap

### Lateral

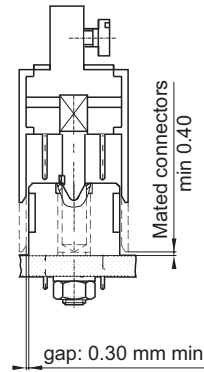

## Tilting

### Longitudinal

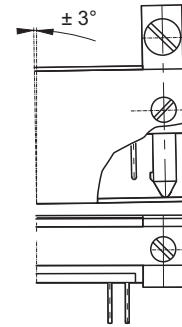

### Lateral

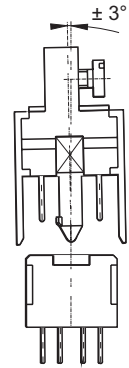

## Mounting Examples

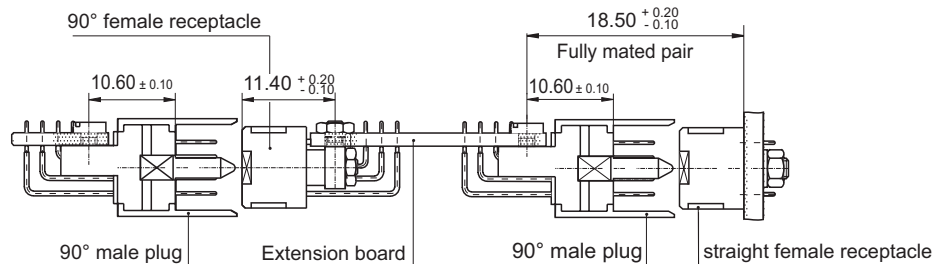
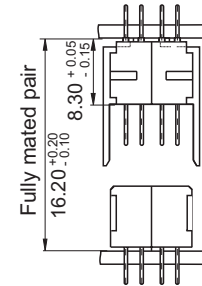
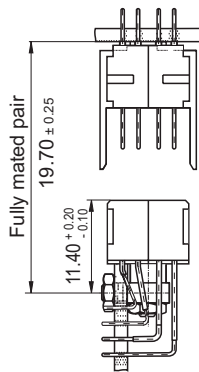
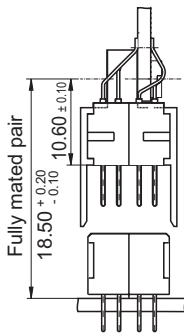

## Displacement

Max displacement allowed while plugging in the receptacle: 0.15 mm in all plugged in connector ways.

# Termination Styles

## Receptacle

### Through board solder - 90°

**Ref: 10**  
PCB: 1.44 - 1.76  
A = 3.25<sup>+0.15</sup><sub>-0.45</sub>  
B = 6 max

**Ref: 11**  
PCB: 1.98 - 2.42  
A = 3.85<sup>+0.15</sup><sub>-0.45</sub>  
B = 6.60 max

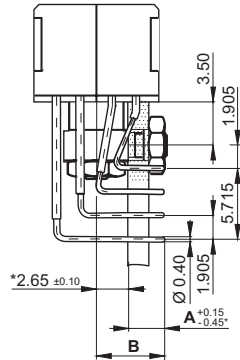

\* Unbuild-up of tolerances

### Through board solder - Straight

**Ref: 30**  
PCB: 2.16 - 2.64  
A = 3.50 min  
A = 4.00 max

**Ref: 31**  
PCB: 2.88 - 5.50  
A = 6.10 min  
A = 6.60 max

**Ref: 96**  
PCB: 3.42 - 4.18  
A = 4.70 min  
A = 5.10 max

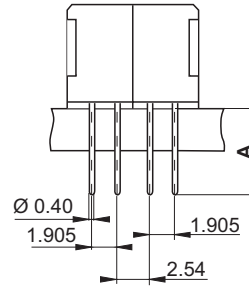

## Plug

### Through board solder - 90°

**Ref: 10**  
PCB: 1.44 - 1.76  
A = 5.95 max

**Ref: 12**  
PCB: 2.88 - 3.52  
A = 7.60 max

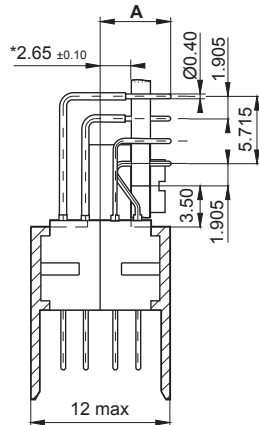

\* Unbuild-up of tolerances

### Through board solder - Straight

**Ref: 30**  
PCB: 2.16 - 2.64  
A = 3.50 min  
A = 4.00 max

**Ref: 31**  
PCB: 2.88 - 3.52  
A = 4.60 min  
A = 5.10 max

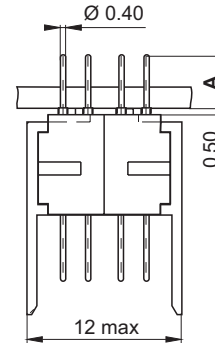

### Surface mount (centered PCB)

**Ref: 41**  
PCB: 1.44 - 1.76  
A = 5.20 max

**Ref: 42**  
PCB: 2.88 - 3.52  
A = 4.40 max

**Ref: 43**  
PCB: 2.16 - 2.64  
A = 4.80 max

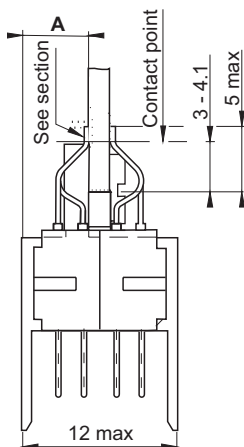

Section of termination  
Mandatory only for  
termination 43, 45 & 47  
(ESCC 3401-065)

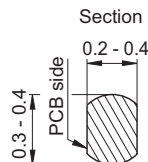

### Surface mount (uncentered PCB)

**Ref: 44**  
PCB: 3.60 - 4.00  
A = 4.40 max

**Ref: 45**  
PCB: 1.44 - 2.40  
A = 7 max

**Ref: 47**  
PCB: 2.16 - 2.70  
A = 7 max

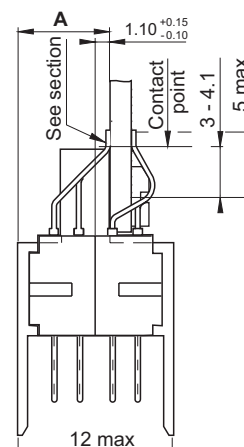



# Connector Dimensions

## Plug

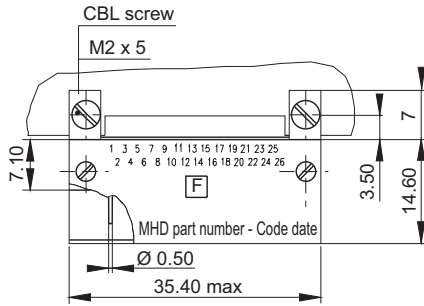

## 52 contacts

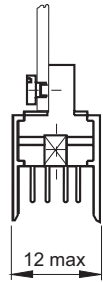

View mating side

## Receptacle

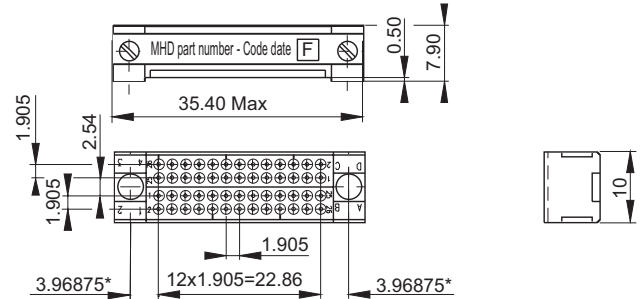

## 100 contacts

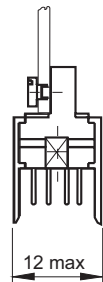
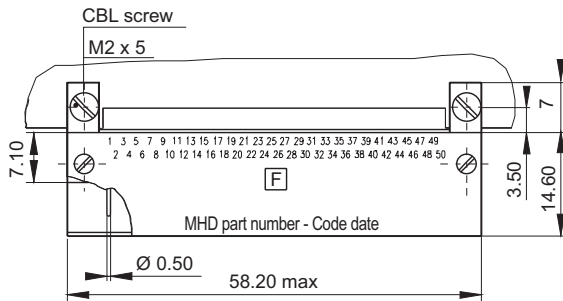

View mating side

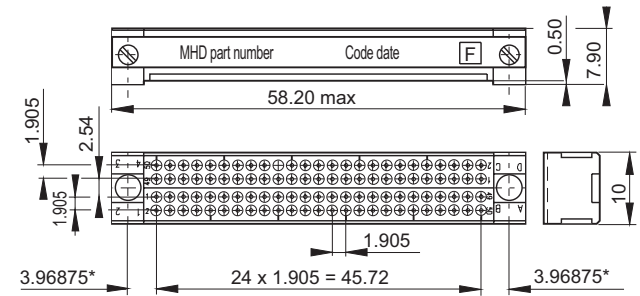

## 5HA

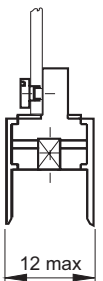
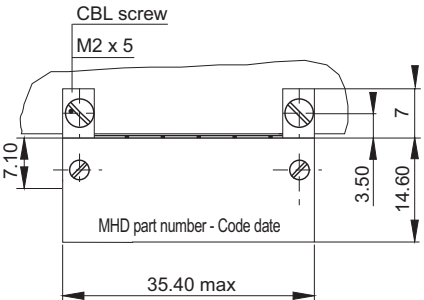

View mating side

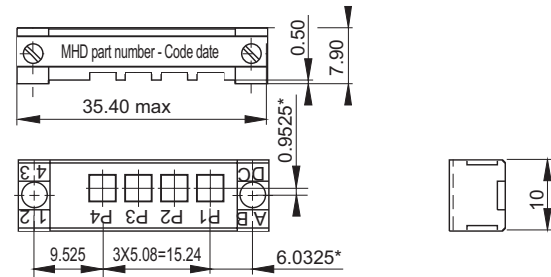

## 1HB

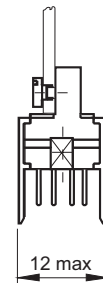
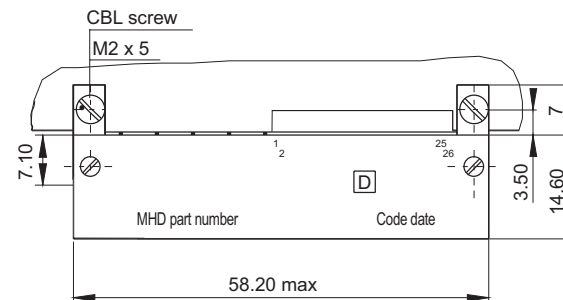

View mating side

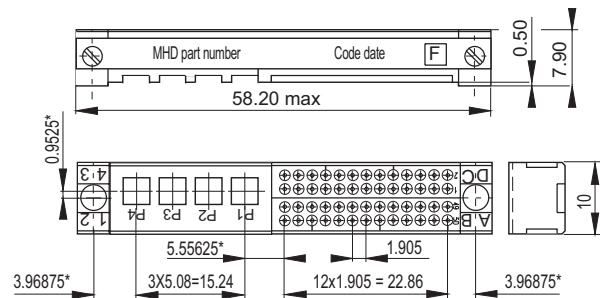

\* Theoretical dimensions

The termination side contact configurations are specified on board preparation details.

## 152 Contacts Plug

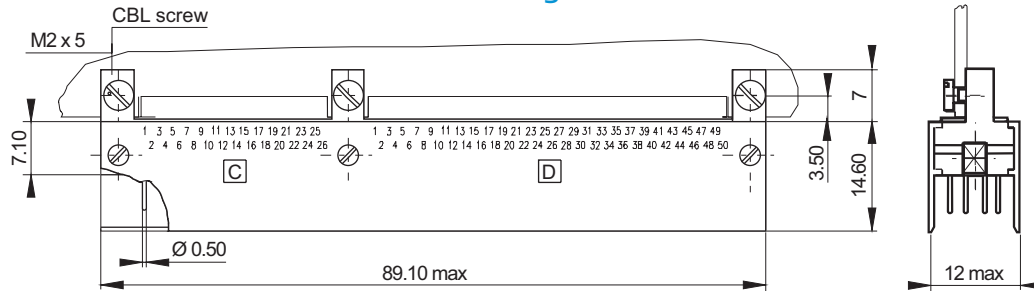

## Receptacle

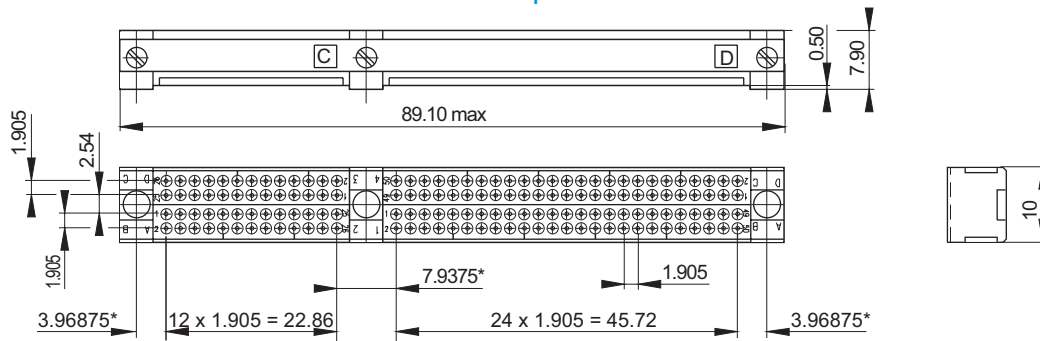

View mating side

## 6XA Plug

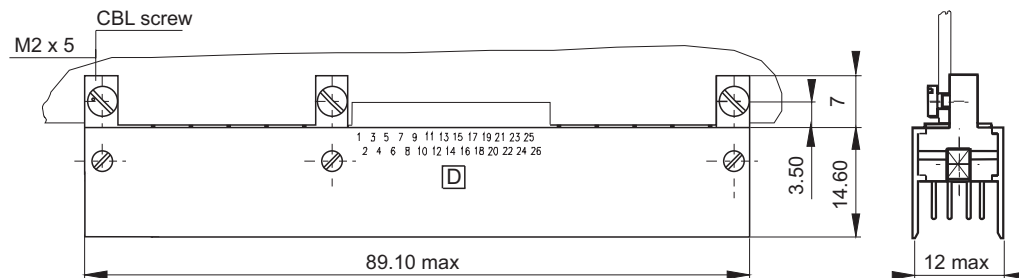

## Receptacle

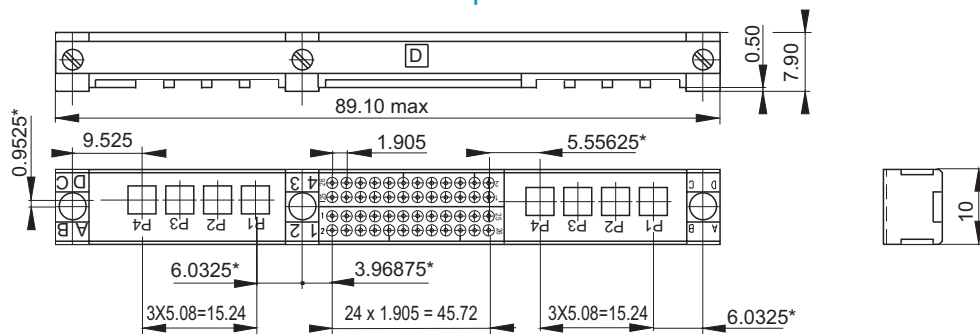

View mating side

\* Theoretical dimensions

The termination side contact configurations are specified on board preparation details.

## 200 Contacts Plug

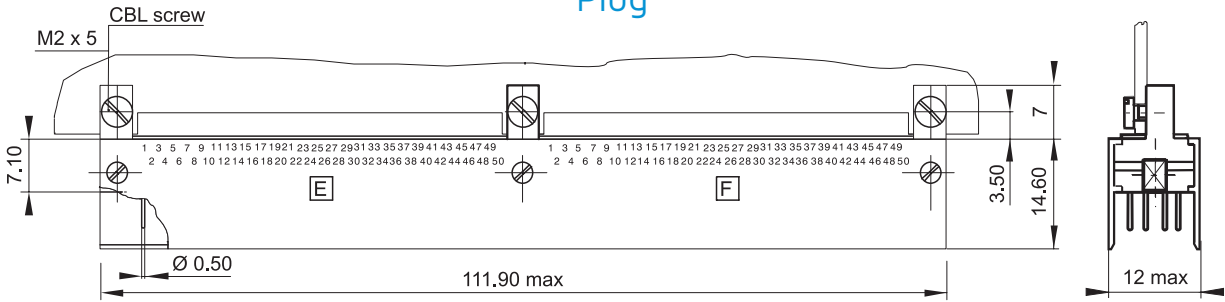

## Receptacle

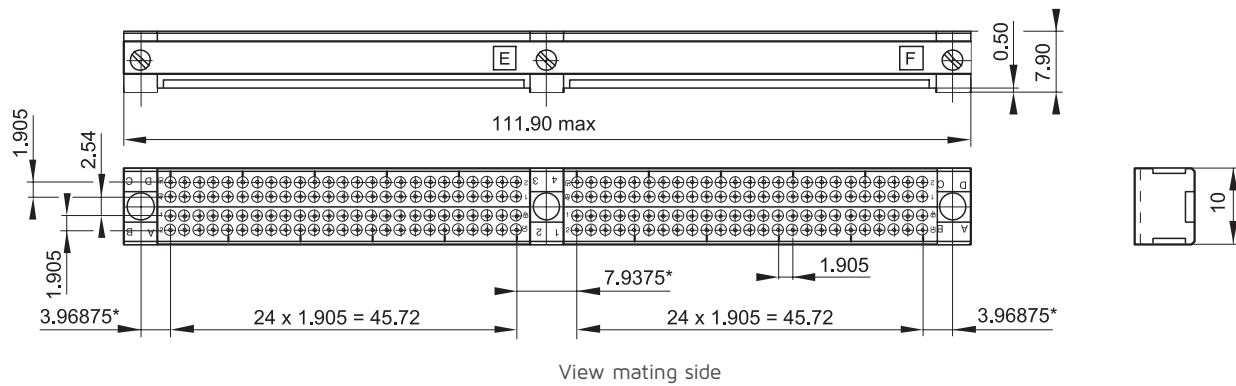

## 2XA Plug

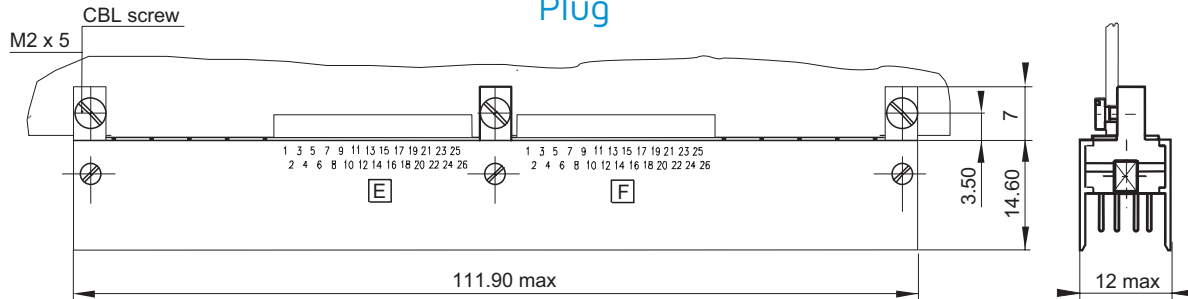

## Receptacle

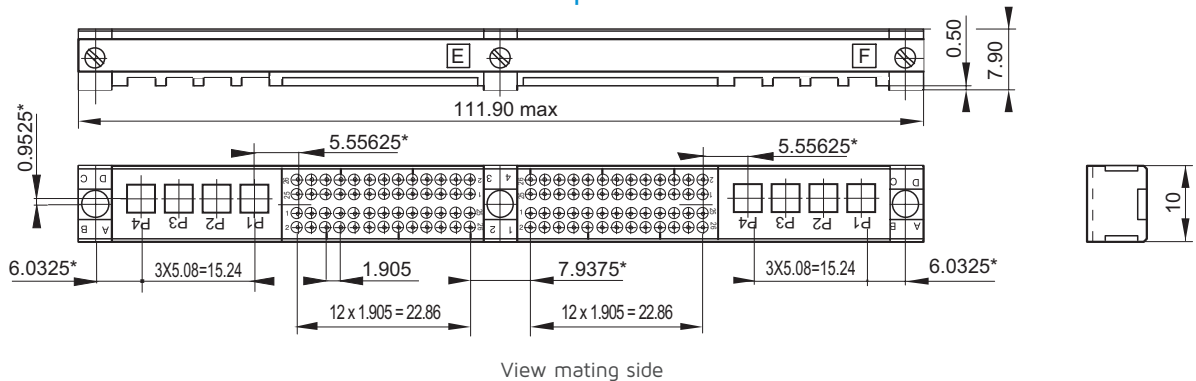

\* Theoretical dimensions

The termination side contact configurations are specified on board preparation details.

## 252 Contacts Plug

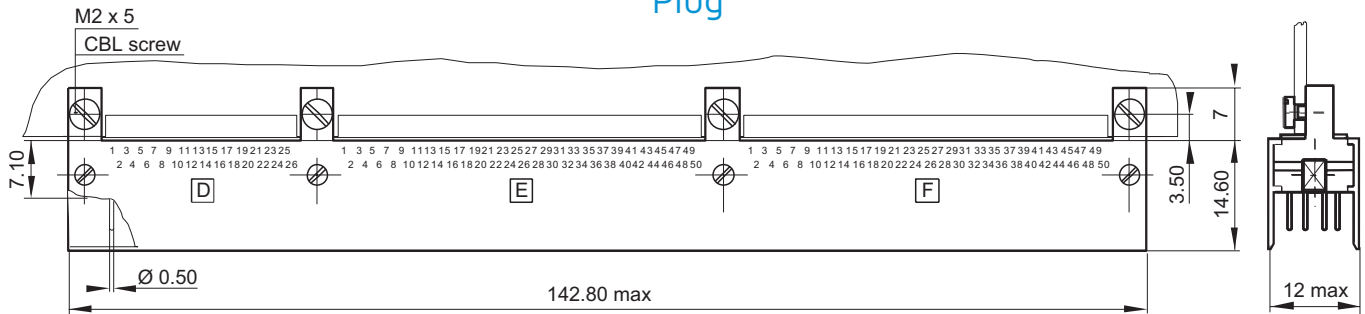

## Receptacle

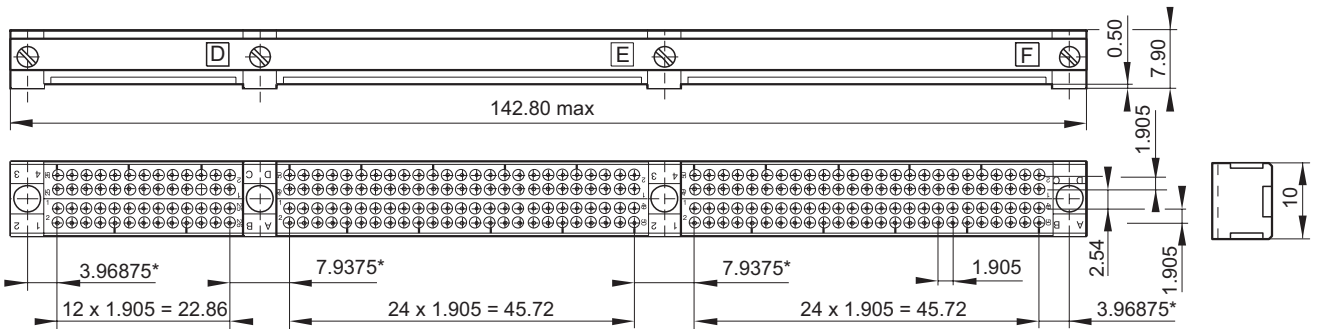

View mating side

## 7XB Plug

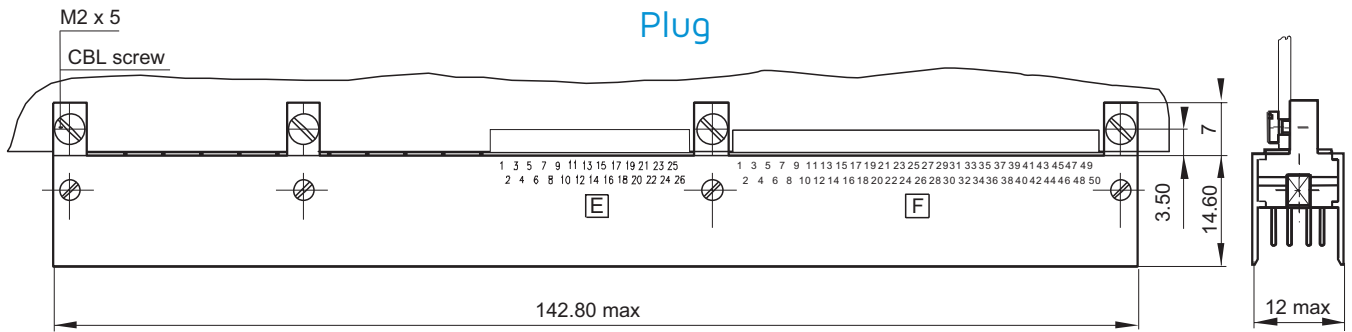

## Receptacle

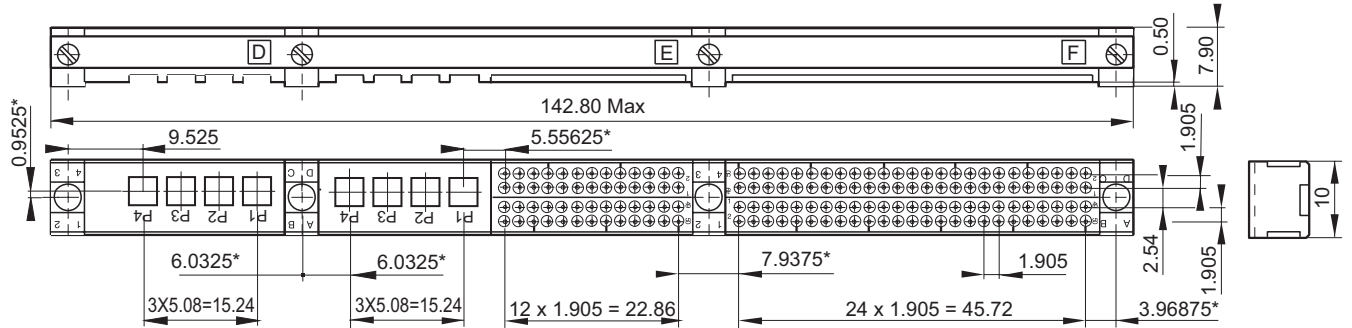

View mating side

\* Theoretical dimensions

The termination side contact configurations are specified on board preparation details.

## 300 Contacts Plug

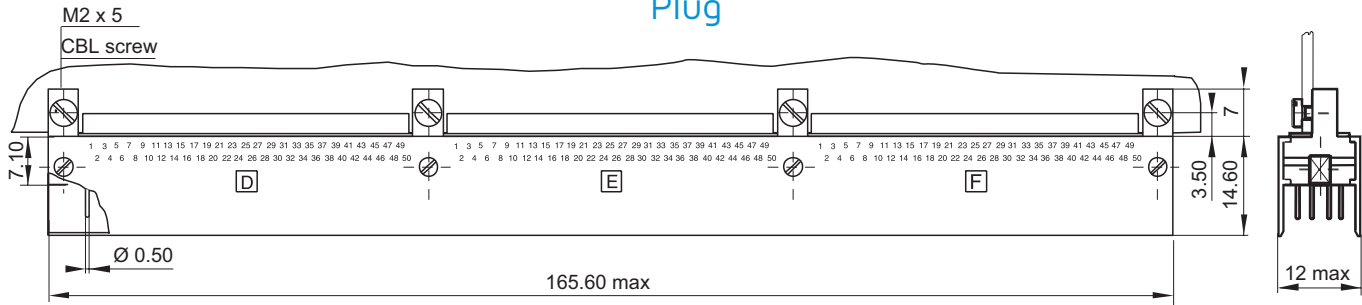

## Receptacle

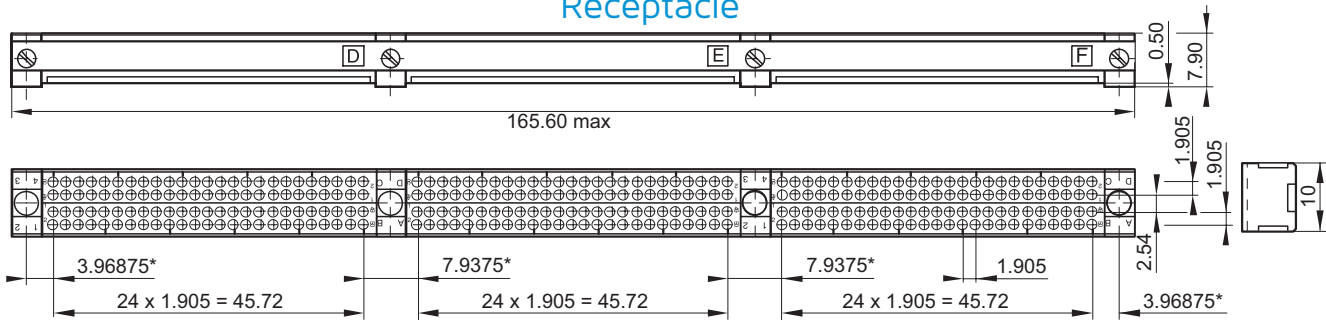

View mating side

## 3HB Plug

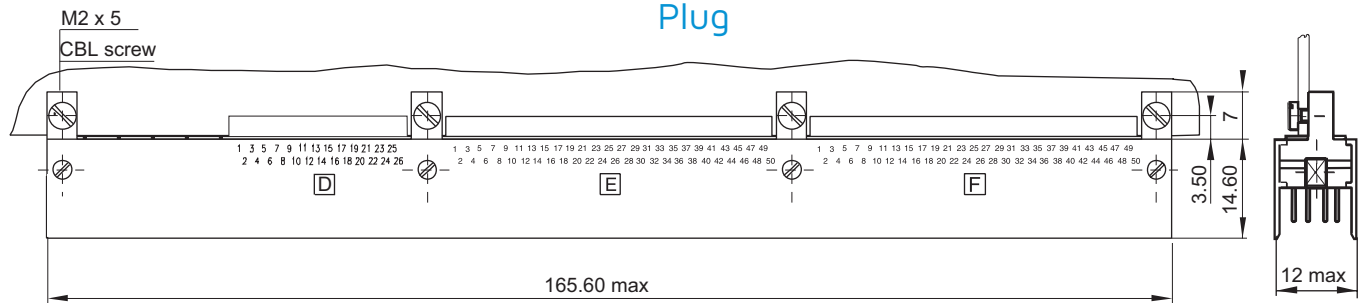

## Receptacle

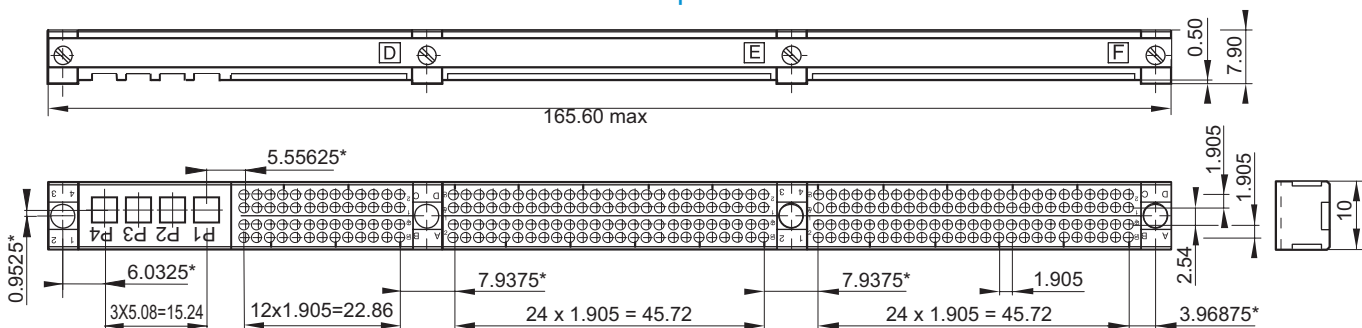

View mating side

\* Theoretical dimensions

The termination side contact configurations are specified on board preparation details.

### 352 Contacts

Plug

Receptacle

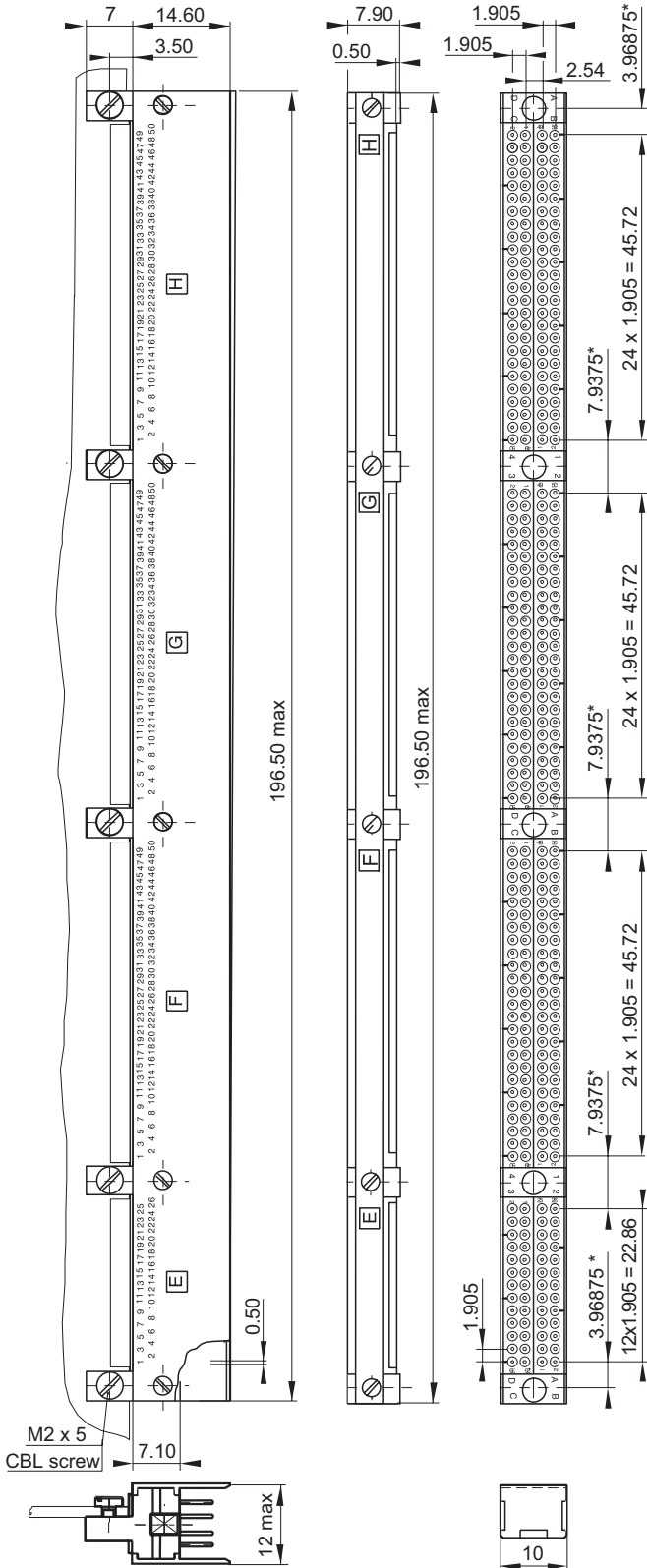

### 400 Contacts

Plug

Receptacle

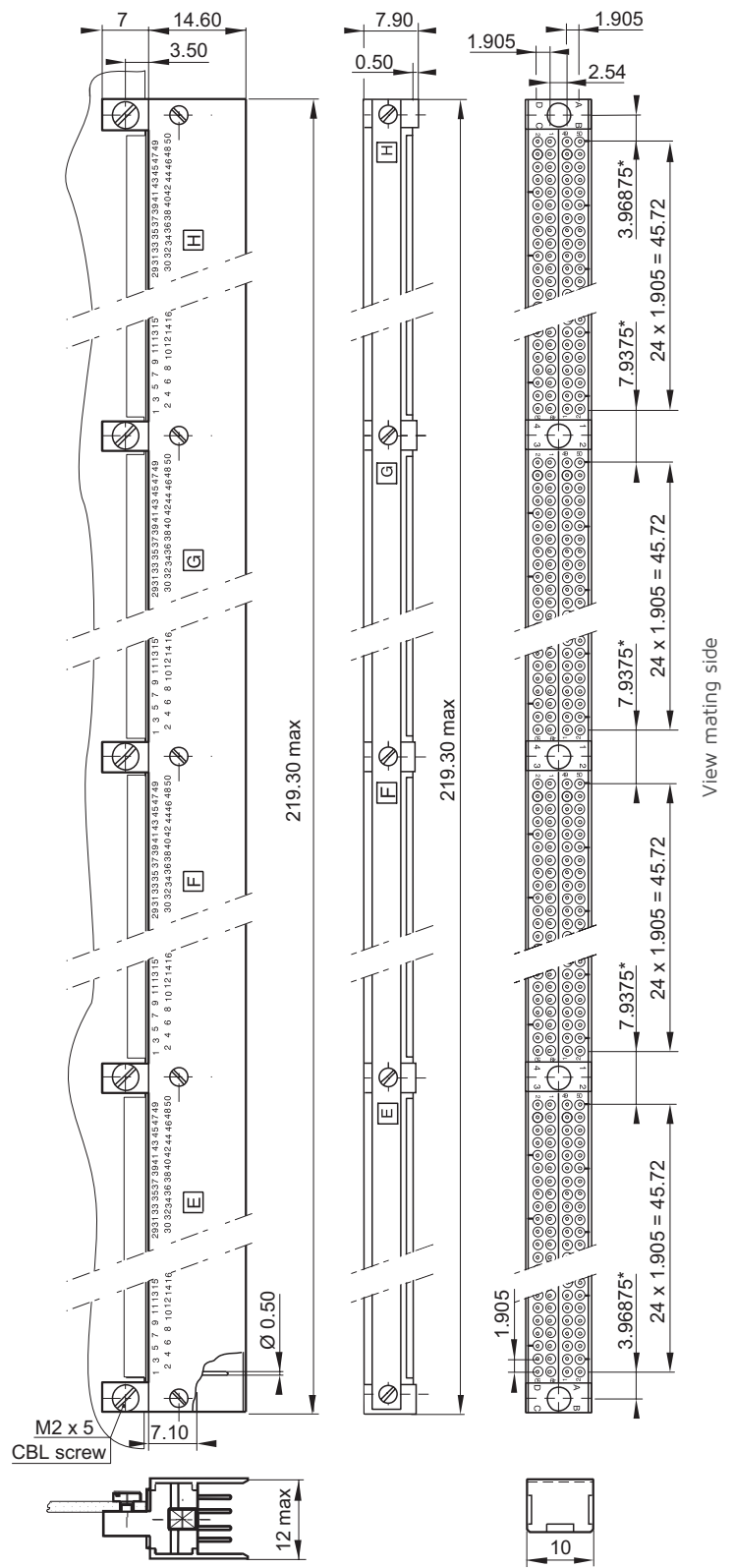

\* Theoretical dimensions

The termination side contact configurations are specified on board preparation details.

# Guiding Devices

## Receptacle

### MHD 00- \_\_ 121

Polarised female guide vertical mounting (Length: 5.50)

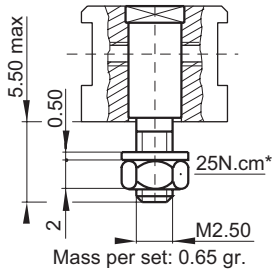

### MHD 00- \_\_ Z122

Polarised female guide vertical mounting (Length: 7)

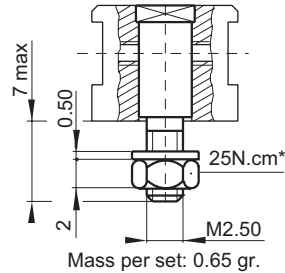

### MHD 00- \_\_ Z124 / Z134

Polarised female guide transverse mounting P/N 124: A=6; 134: A=6.60

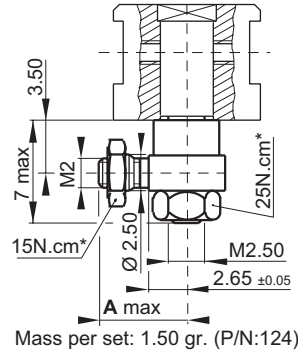

### MHD 00- \_\_ Z126

Unpolarised female guide vertical mounting

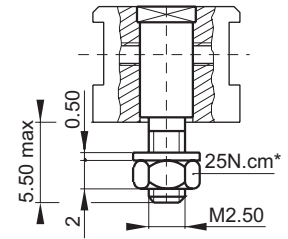

### MHD 00- \_\_ Z130

All polarity female guide vertical mounting (Length: 5.50)

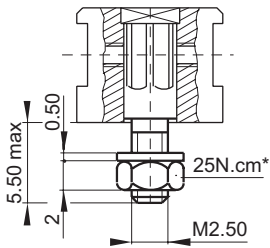

### MHD 00- \_\_ Z131

All polarity female guide vertical mounting (Length: 7)

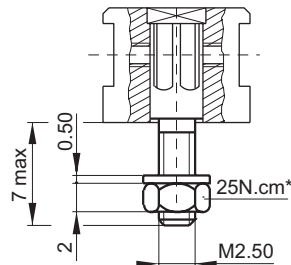

### MHD 00- \_\_ Z133

All polarity female guide transverse mounting

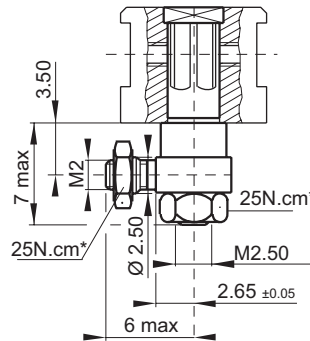

### MHD 00- \_\_ Z190

Ground female guide vertical mounting

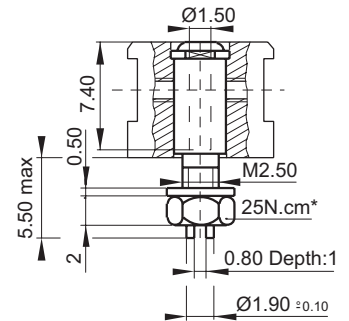

## Plug

### MHD 00- \_\_ 110

Polarised male guide transverse mounting

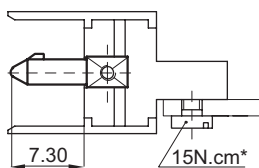

Mass per set: 0.55 gr.

### MHD 00- \_\_ Z111

Polarised male guide vertical mounting

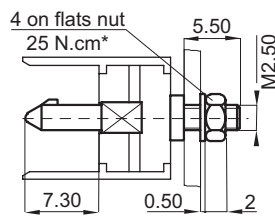

Mass per set: 1.35 gr.

### MHD 00- \_\_ Z125

Unpolarised male guide transverse mounting

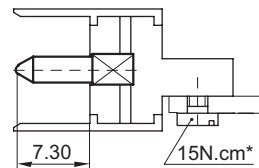

Mass per st: 0.55 gr.

### MHD 00- \_\_ Z191

Ground male contact transverse mounting

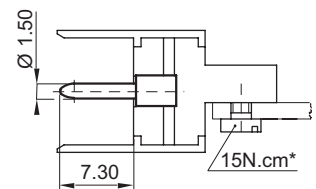

\* Theoretical dimensions

# Contact Board Preparation Details

## 52 Contact Board Preparation Details <sup>(1)</sup> Receptacle

### Straight Termination

Guides: 121, 122, 126, 130, 131, 190

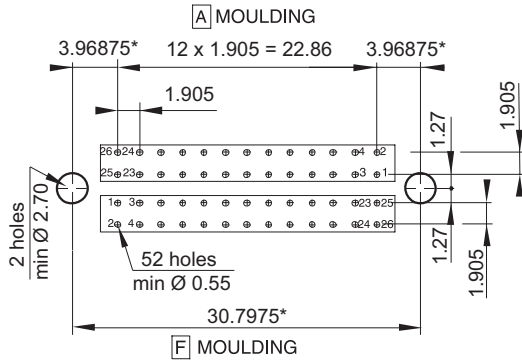

### 90° Termination

Guides: 124, 133, 134

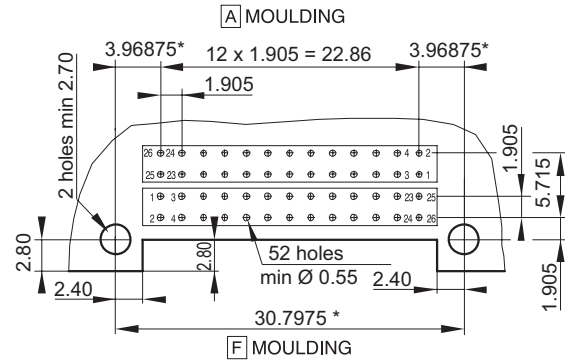

## Plug

### Straight Termination

Guides: 111

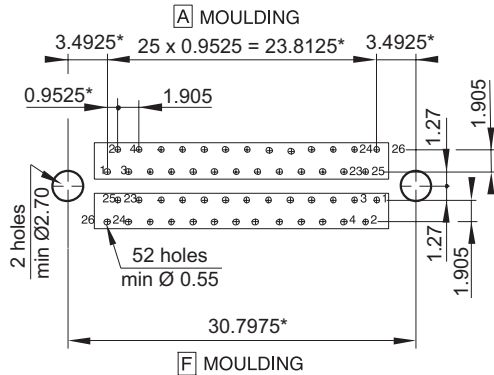

### 90° Termination

Guides: 110, 125, 191

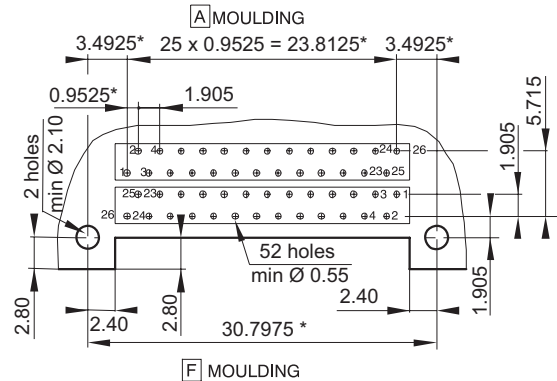

## Surface mount termination

Guides: 110, 125, 191

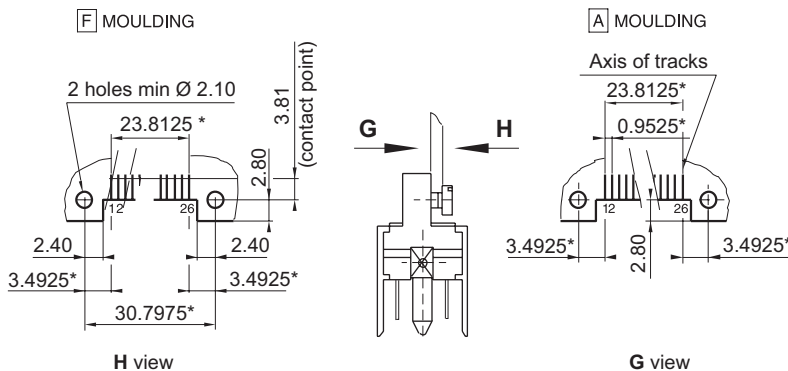

(1) Important note: See important note on 1HB preparation board details (page 17).

\* Theoretical dimensions



# 5HA Contact Board Preparation Details <sup>(1)</sup>

## Receptacle

### Straight Termination

Guides: 121, 122, 126, 130, 131, 190

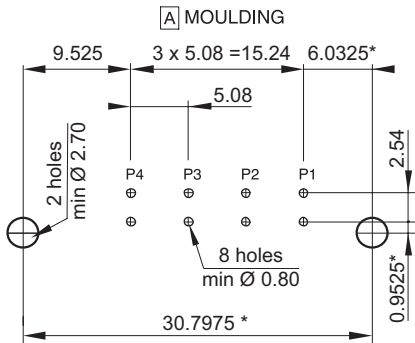

### 90° Termination

Guides: 124, 133, 134

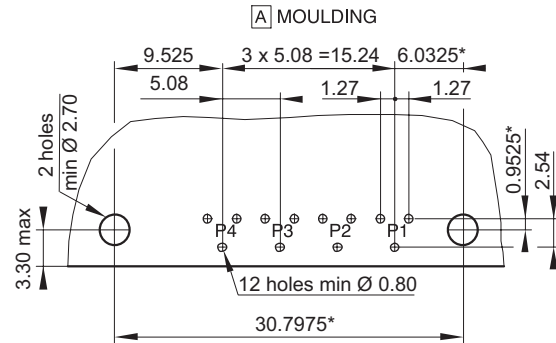

## Plug

### 90° Termination

Guides: 110, 125, 191

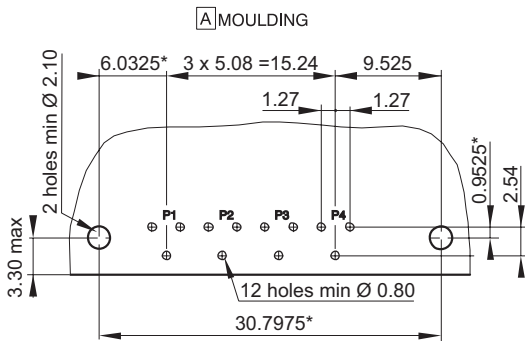

### Surface mount termination

Guides: 110, 125, 191

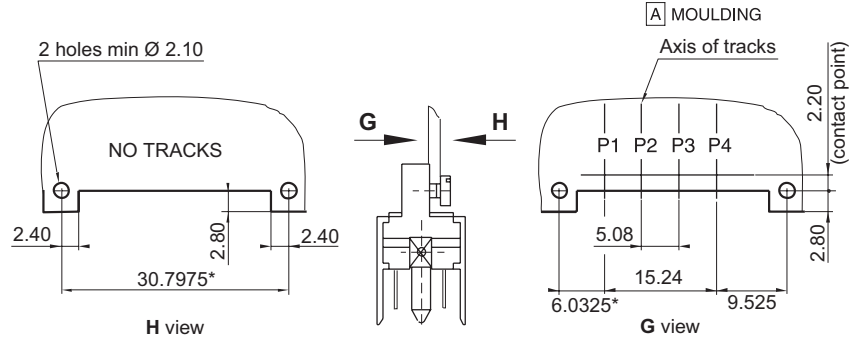

(1) **Important note:** See important note on 1HB preparation board details (page 17).

\* Theoretical dimensions

# 100 Contact Board Preparation Details <sup>(1)</sup>

## Receptacle

### Straight termination

Guides: 121, 122, 126, 130, 131, 190

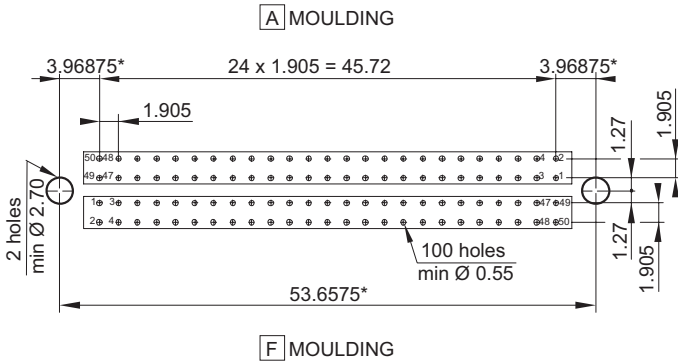

### 90° Termination

Guides: 124, 133, 134

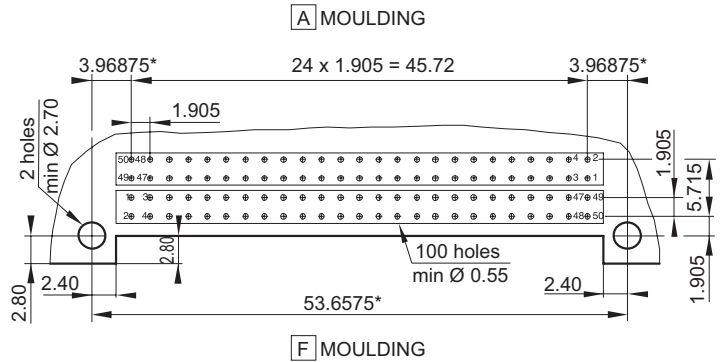

## Plug

### Straight termination

Guides: 111

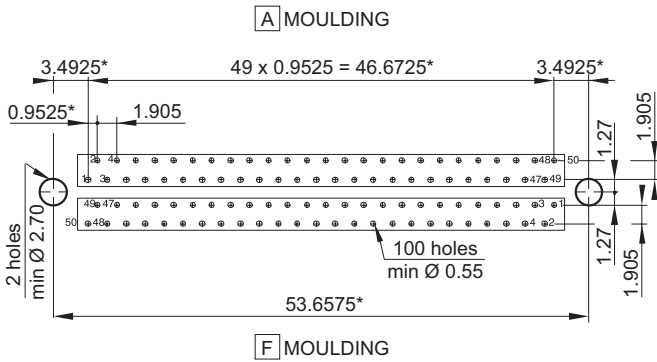

### 90° Termination

Guides: 110, 125, 191

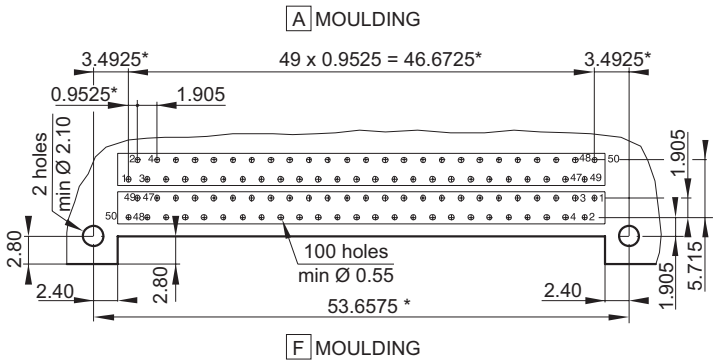

## Surface mount termination

Guides: 110, 125, 191

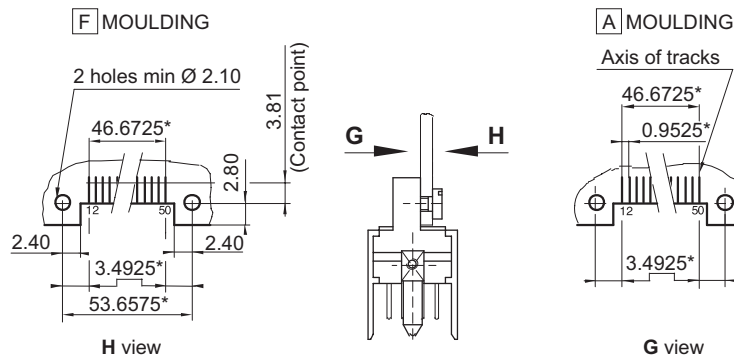

(1) Important note: See important note on 1HB preparation board details (page 17).

\* Theoretical dimensions

# 1HB Contact Board Preparation Details <sup>(1)</sup>

## Receptacle

### Straight termination

Guides: 121, 122, 126, 130, 131, 190

### 90° Termination

Guides: 124, 133, 134

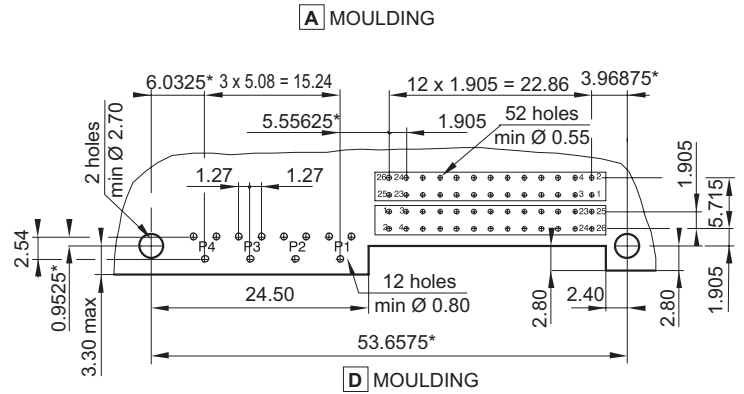
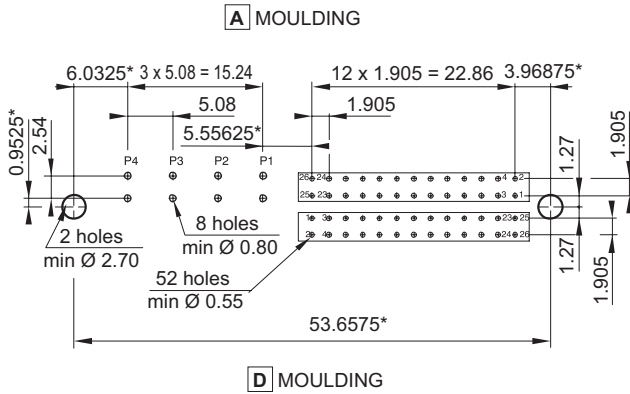

## Plug

### 90° Termination

Guides: 110, 125, 191

### Surface mount termination

Guides: 110, 125, 191

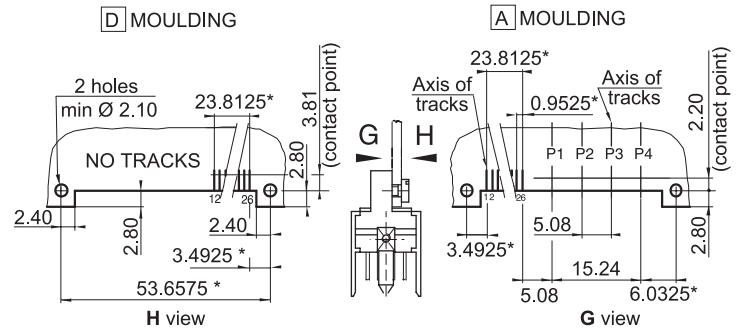
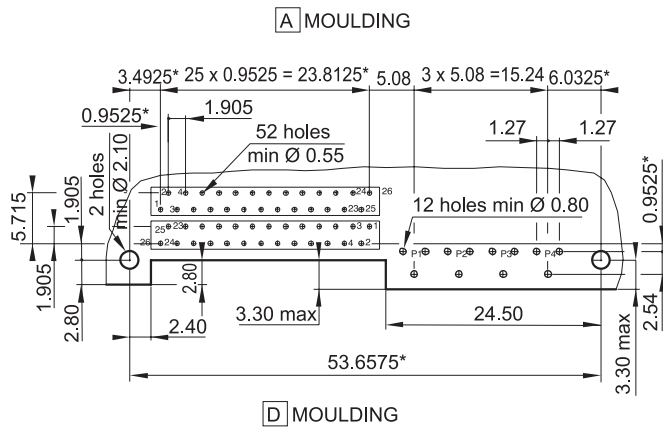

**(1) Important note:** Drilling layouts shown concern the following full configurations: 052, 5HA, 100, 1HB, 200. Other arrangements, shown on "MODULES CONFIGURATION" page, require a specific drilling layout to ensure the correct mounting of the chosen connector, that you must obtain from our technical department. However, the drilling layouts shown above should help you to achieve the desired configuration. For that, you may have to mix those drilling layouts to obtain the right configuration.

\* Theoretical dimensions

# Power & High Frequency Contacts *(NFC 93569)*

## Example of Contact Overview *(020 084 2- 10 RG1)*

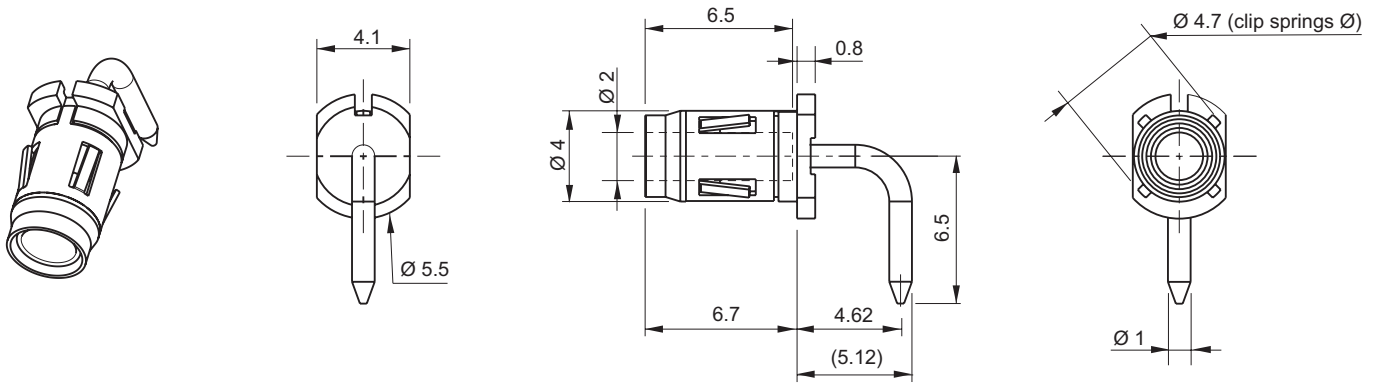

## Power Contacts

Male	P/N
90° termination	020 085 1- 10R OG
Straight termination	020 087 1- 30R OG
Solder bucket termination	020 091 1- 40R OG

Female	P/N
90° termination	020 084 2- 10R G1
Straight termination	020 056 2- 30R G1
Solder bucket termination	020 060 2- 40R G1

## High Frequency Contacts

	Male P/N	Female P/N
Vertical mounting, suitable for flexible cable $\varnothing$ 1.9 max. Ref. KX 21 A (Rg 178 B/U or RG 196).	KMX 3-M 081	KMX 3-F 081
Transverse mounting, suitable for flexible cable $\varnothing$ 1.9 max. Ref. KX 21 A (Rg 178 B/U or RG 196). Usable with mother board, thickness 3.2 mm max.	KMX 3-M 092	KMX 3-F 092
Vertical mounting, suitable for flexible cable $\varnothing$ 2.5 max. Ref. KX 22 A (RG 316).	KMX 3-M 101	KMX 3-F 101
Transverse mounting, suitable for flexible cable $\varnothing$ 2.5 max. Ref. KX 22 A (RG 316). Usable with mother board, thickness 3.2 mm max.	KMX 3-M 112	KMX 3-F 112
Vertical mounting, suitable to semi-rigid cable $\varnothing$ 2.2 max. Ref. Ks 1 A (RG 405 - UT 85).	KMX 3-M 131	KMX 3-F 131
Transverse mounting, suitable to semi-rigid cable $\varnothing$ 2.2 max. Ref. Ks 1 A (RG 405 - UT 85). Usable with mother board, thickness 3.2 mm max.	KMX 3-M 142	KMX 3-F 142
Straight termination tail for direct mounting on to PCB	KMX 3-M 041	KMX 3-F 041
90° termination tail for direct mounting on to PCB	KMX 3-M 032	KMX 3-F 032
SMT termination	KMX 3-M 172	KMX 3-F 172

## Extraction Tools

P/N: SD- 030 00 CX 003

# Technical Characteristics

## Materials & Platings

Insulator	Diallyl Phthalate UL94V0
Frame	Aluminium Alloy
Contact	Copper Alloy
Guide	Brass + Ni plating or Stainless Steel
Contact plating	Ni + Au

## Environmental

Temperature range	- 55° C to +125° C
Safety of contact from extraction	Statical 2 mm / 0.079" Dynamical 1.80 mm / 0.071"
Mating cycles	5000
Withdrawal forces	≤ 0.5 N
Special contacts	According to NFC 93569

## Electrical

Contact resistance	Signal ≤ 12 mΩ
Current rating	Signal 3 A
Insulation	>10 <sup>4</sup> MΩ
Voltage rating	200 V
Proof voltage	800 V
Contact diameter	Signal 0.50 mm

# How To Order



MDD

1

2

3

4

5

<b>1 Series</b>																													
<b>2 Arrangement</b>	1 0 0    2 0 0																												
<b>3 Part - Polarity Plating</b>	<table border="0"> <tr> <td>1 5</td> <td>Male plug - MIL plating</td> <td>2 4</td> <td>Female receptacle - MIL plating</td> </tr> <tr> <td>1 9</td> <td>Male plug - MIL tinned plating</td> <td>2 8</td> <td>Female receptacle - MIL tinned plating</td> </tr> </table>	1 5	Male plug - MIL plating	2 4	Female receptacle - MIL plating	1 9	Male plug - MIL tinned plating	2 8	Female receptacle - MIL tinned plating																				
1 5	Male plug - MIL plating	2 4	Female receptacle - MIL plating																										
1 9	Male plug - MIL tinned plating	2 8	Female receptacle - MIL tinned plating																										
<b>4 Termination Styles</b>	<table border="0"> <tr> <td>1 0</td> <td>90° termination, PCB thickness 1.60</td> <td>1 1</td> <td>90° termination, PCB thickness 2.40</td> </tr> <tr> <td>3 0</td> <td>Straight termination, PCB thickness 2.40</td> <td>3 1</td> <td>Straight termination, PCB thickness 3.20</td> </tr> <tr> <td>4 4</td> <td>SMT* - Uncentered PCB thickness 3.80</td> <td>9 6</td> <td>Straight termination, PCB thickness 4.50</td> </tr> </table>	1 0	90° termination, PCB thickness 1.60	1 1	90° termination, PCB thickness 2.40	3 0	Straight termination, PCB thickness 2.40	3 1	Straight termination, PCB thickness 3.20	4 4	SMT* - Uncentered PCB thickness 3.80	9 6	Straight termination, PCB thickness 4.50																
1 0	90° termination, PCB thickness 1.60	1 1	90° termination, PCB thickness 2.40																										
3 0	Straight termination, PCB thickness 2.40	3 1	Straight termination, PCB thickness 3.20																										
4 4	SMT* - Uncentered PCB thickness 3.80	9 6	Straight termination, PCB thickness 4.50																										
<b>5 Guide Styles</b>	<table border="0"> <tr> <td>1 1 0</td> <td>Male polarised, transverse mount, standard plug</td> <td>1 1 1</td> <td>Male polarised, vertical mount</td> </tr> <tr> <td>1 2 1</td> <td>Female polarised, vertical mount</td> <td>1 2 2</td> <td>Female polarised, vertical mount</td> </tr> <tr> <td>1 2 4</td> <td>Female polarised, transverse mount</td> <td>1 2 5</td> <td>Male unpolarised, transverse mount</td> </tr> <tr> <td>1 2 6</td> <td>Female unpolarised, vertical mount</td> <td>1 3 0</td> <td>Female all polarised, vertical mount</td> </tr> <tr> <td>1 3 1</td> <td>Female all polarised, vertical mount</td> <td>1 3 3</td> <td>Female all polarised, transverse mount</td> </tr> <tr> <td>1 3 4</td> <td>Female polarised, transverse mount</td> <td>1 9 0</td> <td>Female power or mass contact, vertical mount</td> </tr> <tr> <td>1 9 1</td> <td>Male power or mass contact, transverse mount</td> <td>2 0 1</td> <td>¼ turn, free connector</td> </tr> </table>	1 1 0	Male polarised, transverse mount, standard plug	1 1 1	Male polarised, vertical mount	1 2 1	Female polarised, vertical mount	1 2 2	Female polarised, vertical mount	1 2 4	Female polarised, transverse mount	1 2 5	Male unpolarised, transverse mount	1 2 6	Female unpolarised, vertical mount	1 3 0	Female all polarised, vertical mount	1 3 1	Female all polarised, vertical mount	1 3 3	Female all polarised, transverse mount	1 3 4	Female polarised, transverse mount	1 9 0	Female power or mass contact, vertical mount	1 9 1	Male power or mass contact, transverse mount	2 0 1	¼ turn, free connector
1 1 0	Male polarised, transverse mount, standard plug	1 1 1	Male polarised, vertical mount																										
1 2 1	Female polarised, vertical mount	1 2 2	Female polarised, vertical mount																										
1 2 4	Female polarised, transverse mount	1 2 5	Male unpolarised, transverse mount																										
1 2 6	Female unpolarised, vertical mount	1 3 0	Female all polarised, vertical mount																										
1 3 1	Female all polarised, vertical mount	1 3 3	Female all polarised, transverse mount																										
1 3 4	Female polarised, transverse mount	1 9 0	Female power or mass contact, vertical mount																										
1 9 1	Male power or mass contact, transverse mount	2 0 1	¼ turn, free connector																										

\* Surface Mount Termination  
PCB thickness is in mm

# Modules Configuration

## Receptacle - Mating Side Views Single arrangements

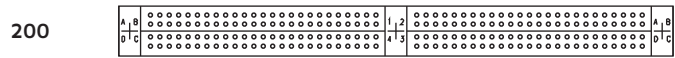
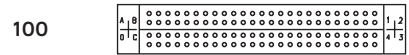

50 ways module

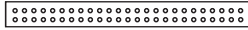

# Standard Plugging Stages

## Misalignment

Longitudinal

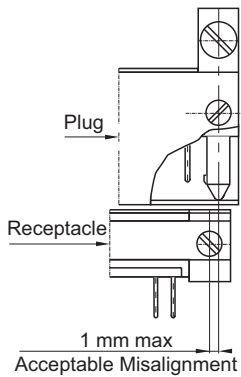

Lateral

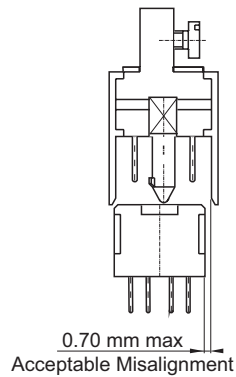

## Gap

Lateral

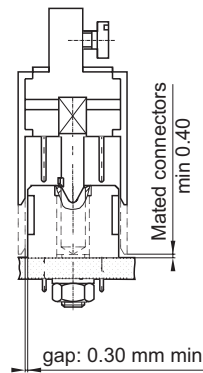

## Tilting

Longitudinal

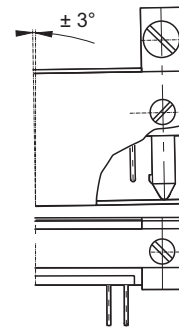

Lateral

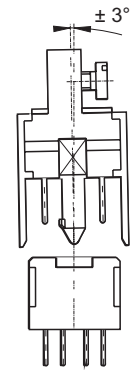

## Mounting Examples

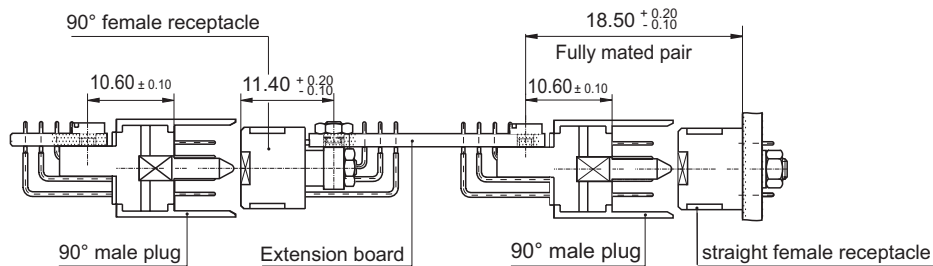
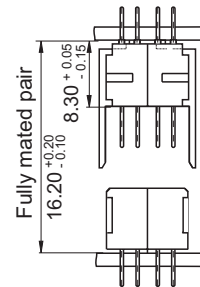
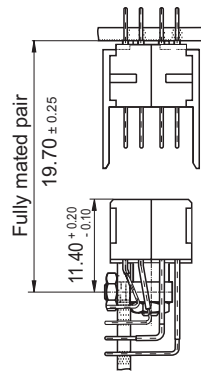
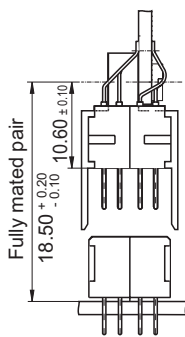

## Displacement

Max displacement allowed while plugging in the receptacle: 0.15 mm in all plugged in connector ways.



# Termination Styles

## Receptacle

### Through board solder - 90°

**Ref: 10**  
PCB: 1.44 - 1.76  
 $A = 3.25^{+0.15}_{-0.45}$   
 $B = 6 \text{ max}$

**Ref: 11**  
PCB: 1.98 - 2.42  
 $A = 3.85^{+0.15}_{-0.45}$   
 $B = 6.60 \text{ max}$

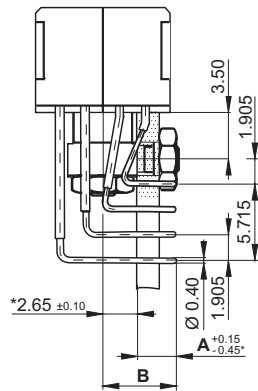

\* Unbuild-up of tolerances

### Through board solder - Straight

**Ref: 30**  
PCB: 2.16 - 2.64  
 $A = 3.50 \text{ min}$   
 $4.00 \text{ max}$

**Ref: 31**  
PCB: 2.88 - 5.50  
 $A = 6.10 \text{ min}$   
 $6.60 \text{ max}$

**Ref: 96**  
PCB: 3.42 - 4.18  
 $A = 4.70 \text{ min}$   
 $5.10 \text{ max}$

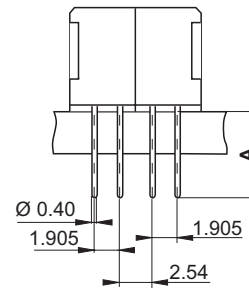

## Plug

### Through board solder - 90°

**Ref: 10**  
PCB: 1.44 - 1.76  
 $A = 5.95 \text{ max}$

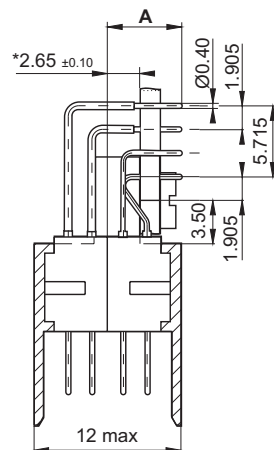

\* Unbuild-up of tolerances

### Through board solder - Straight

**Ref: 30**  
PCB: 2.16 - 2.64  
 $A = 3.50 \text{ min}$   
 $4.00 \text{ max}$

**Ref: 31**  
PCB: 2.88 - 3.52  
 $A = 4.60 \text{ min}$   
 $5.10 \text{ max}$

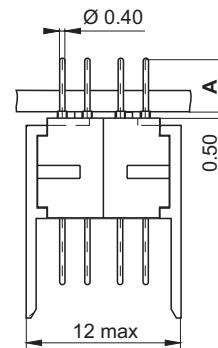

## Surface Mount (uncentered PCB)

**Ref: 44**  
PCB: 3.60 - 4.00  
 $A = 4.40 \text{ max}$

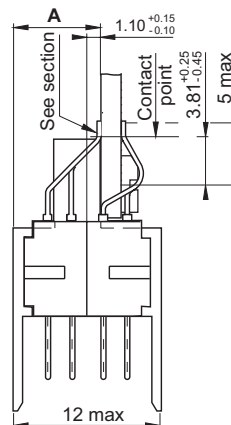

# Connector Dimensions

## 100 Contacts Plug

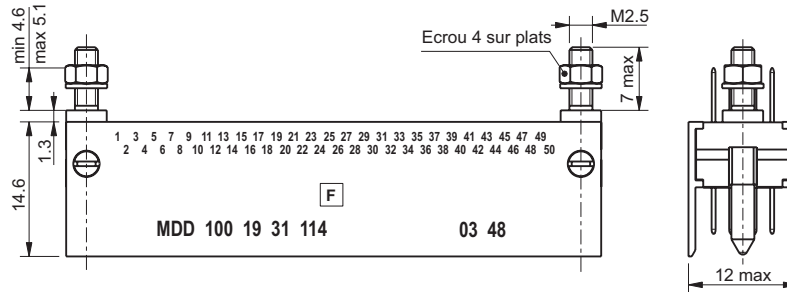

## Receptacle

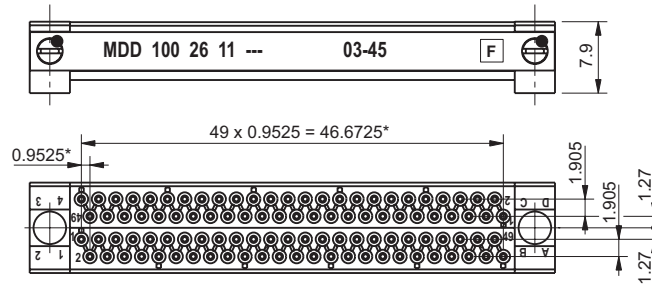

## 200 Contacts Plug

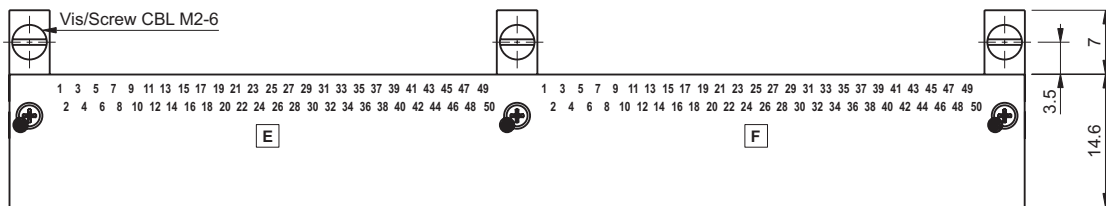

## Receptacle

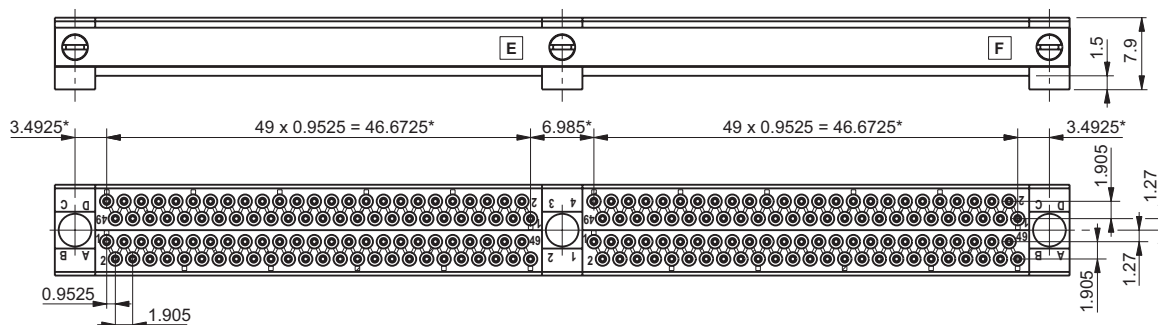

\* Theoretical dimensions

# Guiding Devices

## Receptacle

### MHD 00- \_\_ 121

Polarised female guide vertical mounting (Length: 5.50)

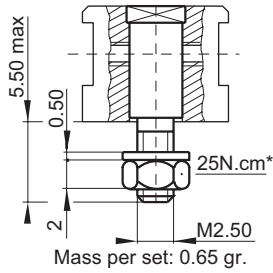

### MHD 00- \_\_ Z122

Polarised female guide vertical mounting (Length: 7)

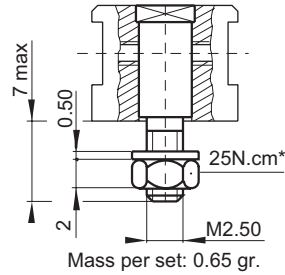

### MHD 00- \_\_ Z124 / Z134

Polarised female guide transverse mounting P/N 124: A=6; 134: A=6.60

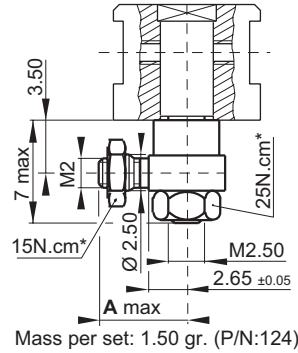

### MHD 00- \_\_ Z126

Unpolarised female guide vertical mounting

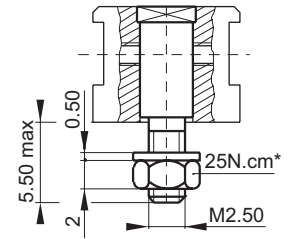

### MHD 00- \_\_ Z130

All polarity female guide vertical mounting (Length: 5.50)

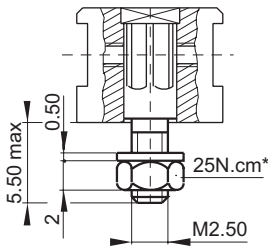

### MHD 00- \_\_ Z131

All polarity female guide vertical mounting (Length: 7)

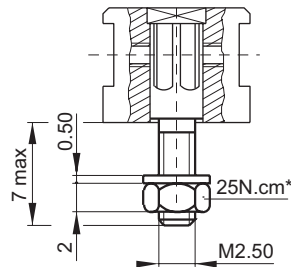

### MHD 00- \_\_ Z133

All polarity female guide transverse mounting

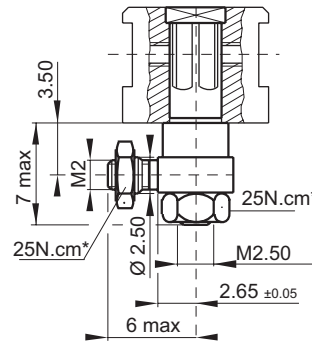

### MHD 00- \_\_ Z190

Ground female guide vertical mounting

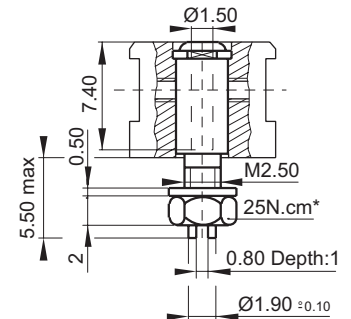

## Plug

### MHD 00- \_\_ 110

Polarised male guide transverse mounting

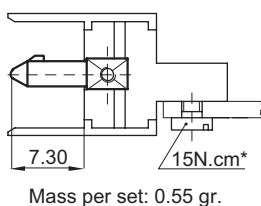

### MHD 00- \_\_ Z111

Polarised male guide vertical mounting

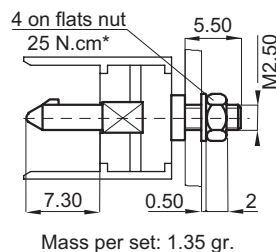

### MHD 00- \_\_ Z125

Unpolarised male guide transverse mounting

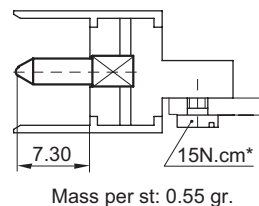

### MHD 00- \_\_ Z191

Ground male contact transverse mounting

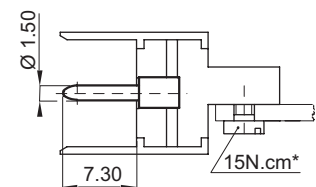

\* Theoretical dimensions

# Contact Board Preparation Details

## 100 Contact Board Preparation Details <sup>(1)</sup>

### Receptacle

#### Straight termination

Guides: 121, 122, 126, 130, 131, 190

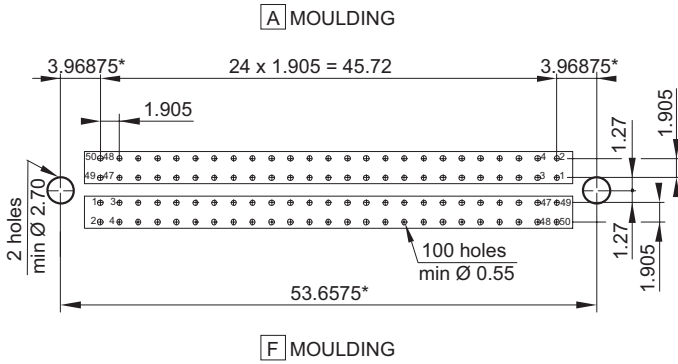

#### 90° Termination

Guides: 124, 133, 134

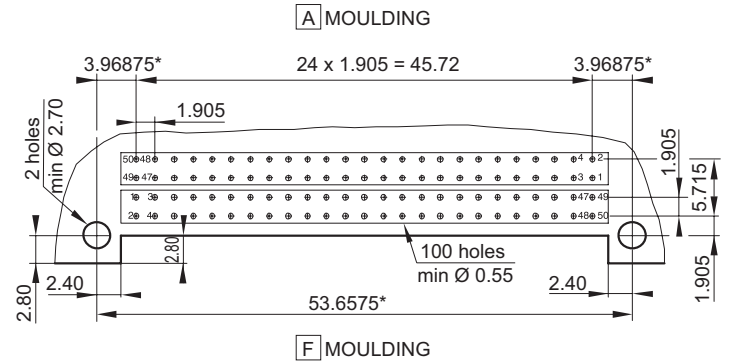

### Plug

#### Straight termination

Guides: 111

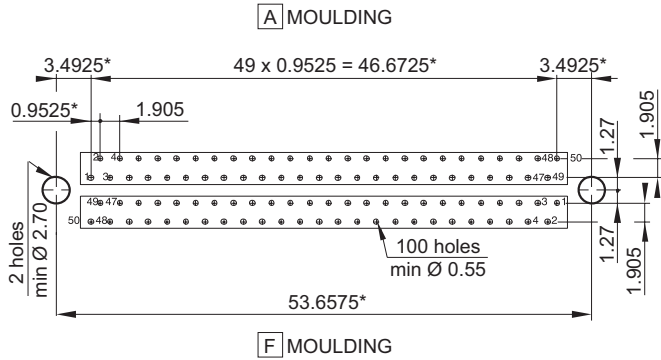

#### 90° Termination

Guides: 110, 125, 191

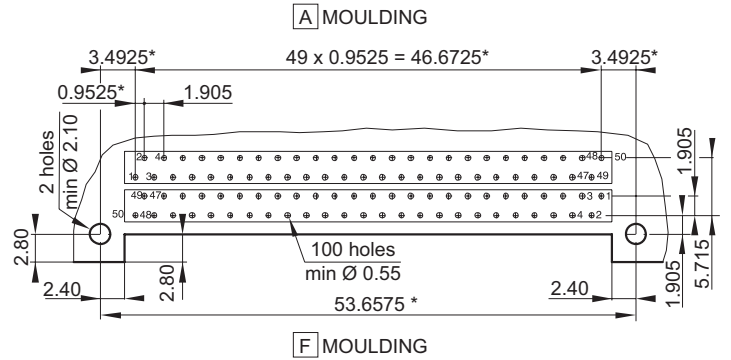

### Surface mount termination

Guides: 110, 125, 191

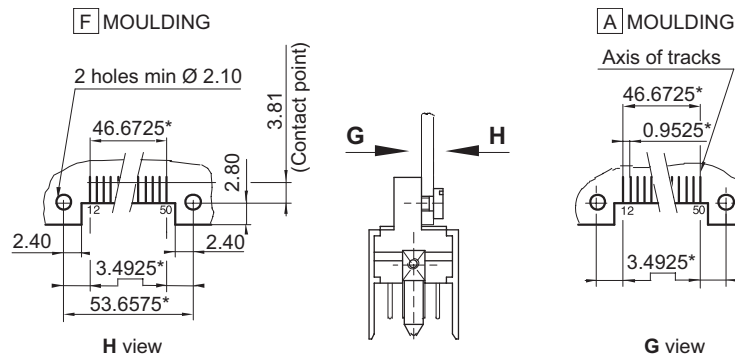

(1) Important note: See important note on 1HB preparation board details (page 17).

\* Theoretical dimensions

# Technical Characteristics

## Materials & Platings

Insulator	LCP Thermoplastic
Contact	Copper Alloy
Guide	Brass + Ni plating or Stainless Steel
Contact plating	Ni + Au

## Environmental

Temperature range	- 55° C to +125° C
Safety of contact from extraction	Statical 2 mm / 0.079" Dynamical 1.80 mm / 0.071"
Mating cycles	5000
Withdrawal forces	≤ 0.5 N
Special contacts	According to NFC 93569

## Electrical

Contact resistance	Signal ≤ 12 mΩ
Current rating	Signal 3 A
Insulation	>10 <sup>4</sup> MΩ
Voltage rating	200 V
Proof voltage	800 V
Contact diameter	Signal 0.50 mm

# How To Order



MDP

1



2



3



4



5

<b>1 Series</b>					
<b>2 Arrangement</b>	2 0 0				
<b>3 Part - Polarity Plating</b>	<table border="0"> <tr> <td>1 9 Male plug - MIL tinned plating</td> <td>2 8 Female receptacle - MIL tinned plating</td> </tr> </table>	1 9 Male plug - MIL tinned plating	2 8 Female receptacle - MIL tinned plating		
1 9 Male plug - MIL tinned plating	2 8 Female receptacle - MIL tinned plating				
<b>4 Termination Styles</b>	<table border="0"> <tr> <td>1 0 90° termination, PCB thickness 1.60</td> <td>4 4 SMT* - Uncentered PCB thickness 3.80</td> </tr> <tr> <td>3 1 Straight termination, PCB thickness 3.20</td> <td>9 6 Straight termination, PCB thickness 4.50</td> </tr> </table>	1 0 90° termination, PCB thickness 1.60	4 4 SMT* - Uncentered PCB thickness 3.80	3 1 Straight termination, PCB thickness 3.20	9 6 Straight termination, PCB thickness 4.50
1 0 90° termination, PCB thickness 1.60	4 4 SMT* - Uncentered PCB thickness 3.80				
3 1 Straight termination, PCB thickness 3.20	9 6 Straight termination, PCB thickness 4.50				
<b>5 Guide Styles</b>	<table border="0"> <tr> <td>1 1 4 Male unpolarised, vertical mount</td> <td>1 2 2 Female polarised, vertical mount</td> </tr> <tr> <td>1 2 5 Male unpolarised, transverse mount</td> <td>1 3 4 Female polarised, transverse mount</td> </tr> </table>	1 1 4 Male unpolarised, vertical mount	1 2 2 Female polarised, vertical mount	1 2 5 Male unpolarised, transverse mount	1 3 4 Female polarised, transverse mount
1 1 4 Male unpolarised, vertical mount	1 2 2 Female polarised, vertical mount				
1 2 5 Male unpolarised, transverse mount	1 3 4 Female polarised, transverse mount				

\* Surface Mount Termination  
PCB thickness is in mm

# Connector Dimensions

## 200 Contacts Plug

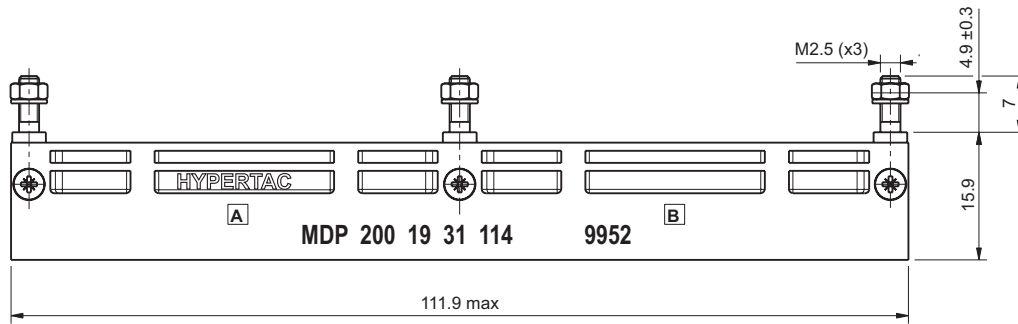

## Receptacle

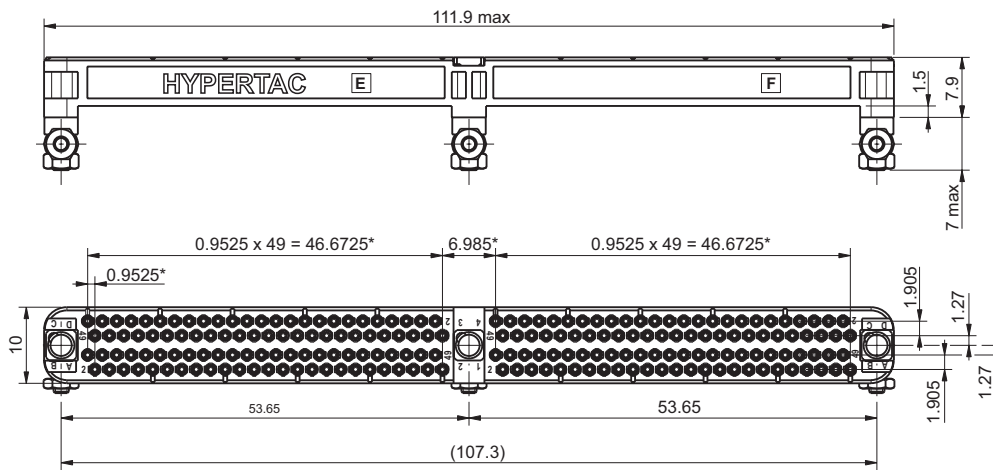

\* Theoretical dimensions

# Guide and Termination Styles

## Receptacle

Through board solder - 90°

Guide: 134

Ref: 10  
PCB: 1.44 - 1.76

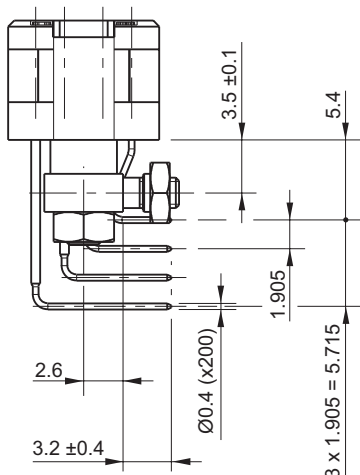

Through board solder - Straight

Guide: 122

Ref: 96  
PCB: 3.42 - 4.18

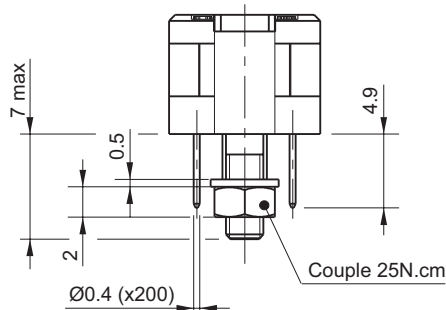

## Plug

Through board solder - Straight

Guide: 114

Ref: 44  
PCB: 3.60 - 4.00

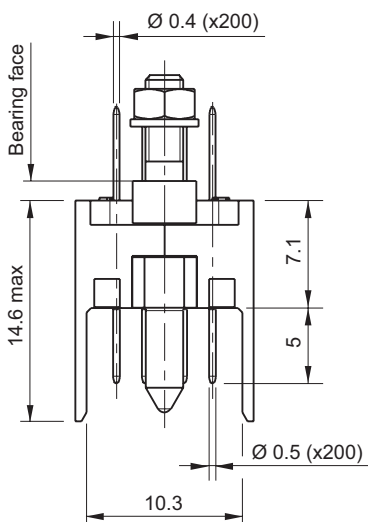

Surface mount (uncentered PCB)

Guide: 125

Ref: 81  
PCB: 2.88 - 3.52

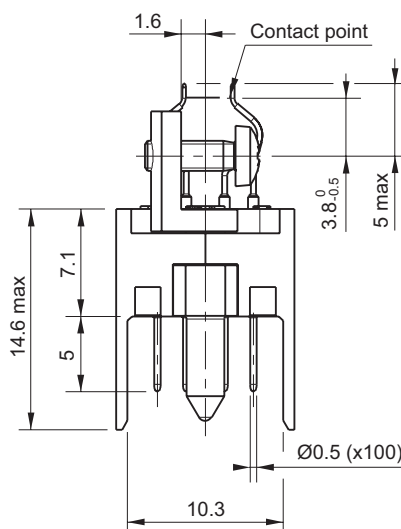

Note: for other guide styles requested, please contact technical support.



# Contact Board Preparation Details

## 200 Contact Board Preparation Details Receptacle

### Straight termination

Guide: 122

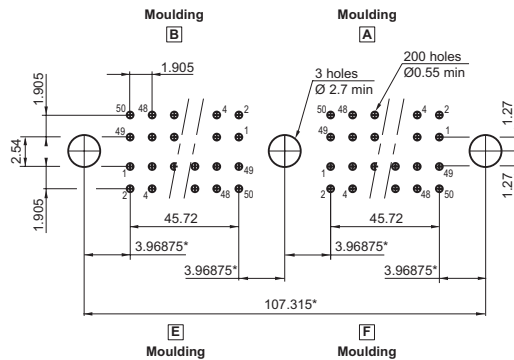

### 90° Termination

Guide: 134

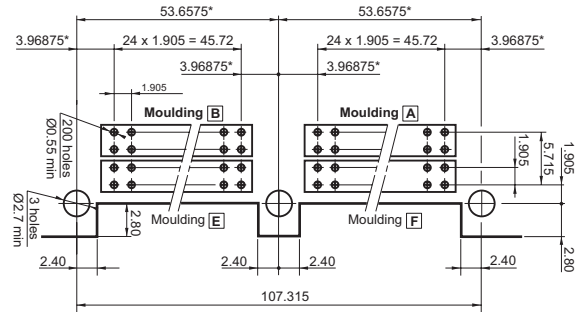

## Plug

### Straight termination

Guide: 114

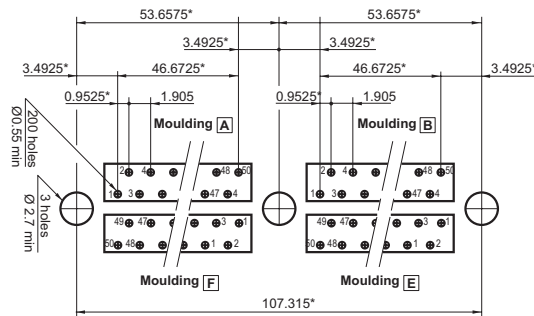

### Surface mount termination

Guide: 125

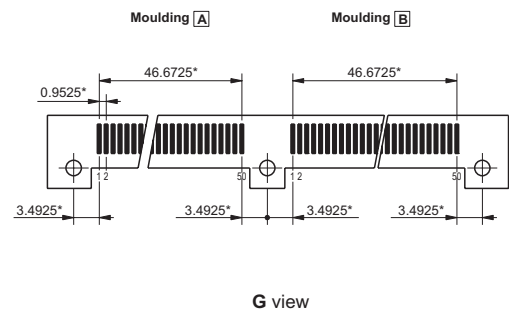
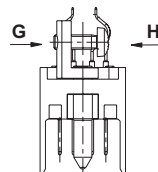
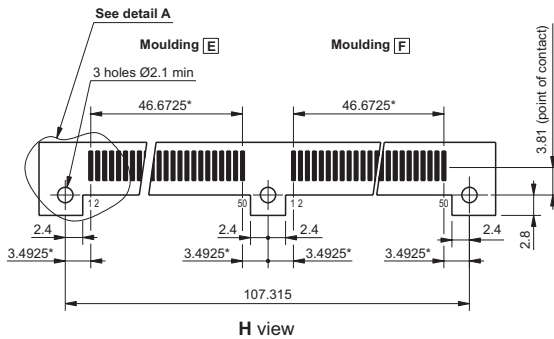

\* Theoretical dimensions

## Disclaimer 2018

All of the information included in this catalogue is believed to be accurate at the time of printing. It is recommended, however, that users should independently evaluate the suitability of each product for their intended application and be sure that each product is properly installed, used and maintained to achieve desired results.

Smiths Interconnect makes no warranties as to the accuracy or completeness of the information, and disclaims any liability regarding its use.

Smiths Interconnect reserves the right to modify design and specifications, in order to improve quality, keep pace with technological development or meet specific production requirements.

No reproduction or use without express permission of editorial and pictorial content, in any manner.

# Product Portfolio

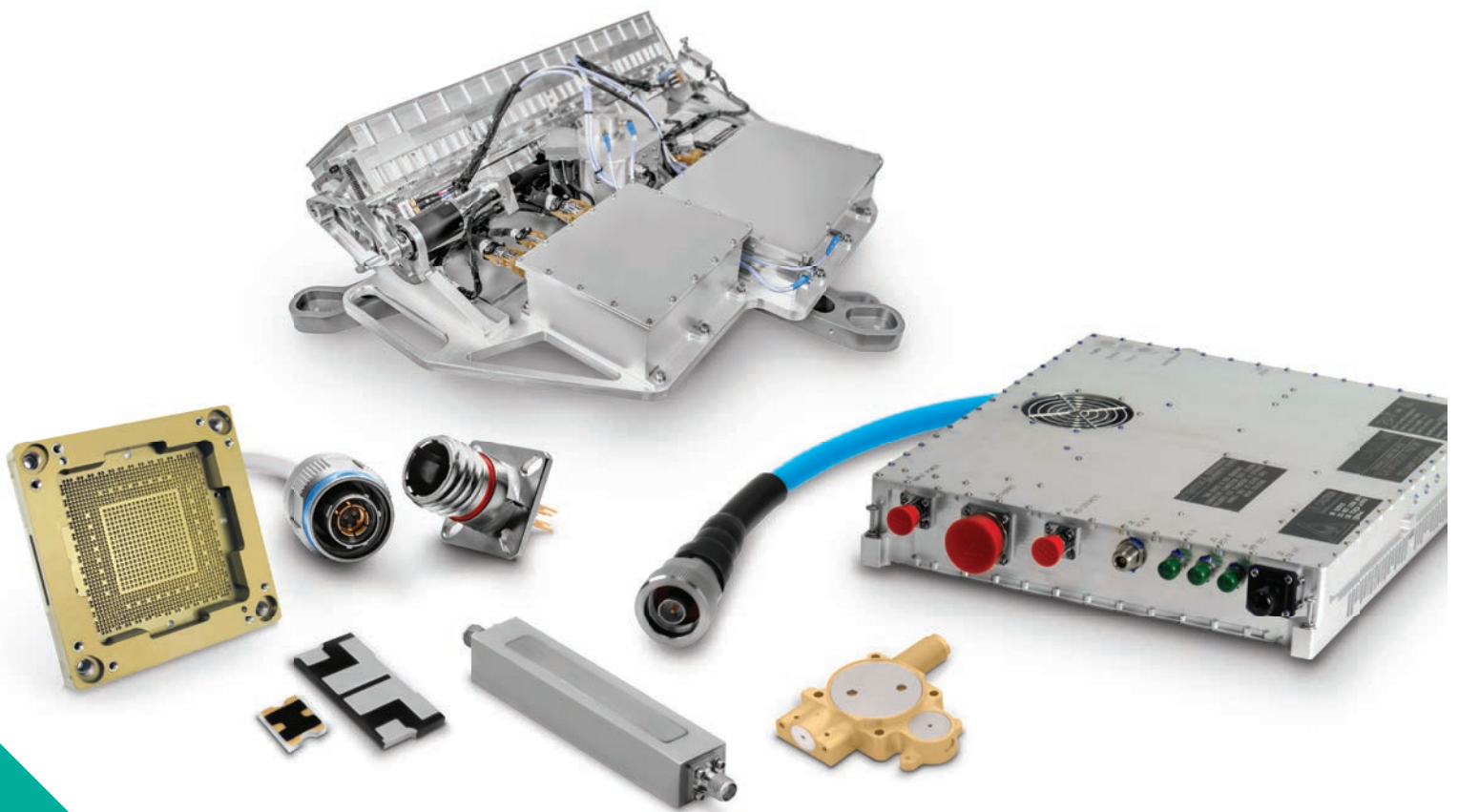

- Antenna Systems
- Cable Assemblies
- Connector Solutions
- Ferrite Components & Assemblies
- RF Filter Components & Assemblies
- Integrated Microwave Assemblies
- Millimeter-Wave Solutions
- RF Components
- Test Sockets and WLCSP Probe Heads
- Time & Frequency Systems

# Global Support

## UK Headquarters

- London, UK  
+44 20 7004 1600  
info.uk@smithsinterconnect.com

## US Headquarters

- Stuart, FL  
+1 772 286 9300  
info.us@smithsinterconnect.com

## Americas

- Costa Mesa, CA  
+1 714 371 1100  
info.us@smithsinterconnect.com
- Milpitas, CA  
+1 408 957 9607 x 1125  
info.us@smithsinterconnect.com
- Stuart, FL  
+1 772 286 9300  
info.us@smithsinterconnect.com
- Hudson, MA  
+1 978 568 0451  
info.us@smithsinterconnect.com
- Northampton, MA  
+1 413 582 9620  
info.northampton@smithsinterconnectinc.com
- Tampa, FL  
+ 1 813 901 7200  
info.tampa@smithsinterconnectinc.com
- Kansas City, KS  
+1 913 342 5544  
info.us@smithsinterconnect.com
- Salisbury, MD  
+1 800 780 2169  
info.us@smithsinterconnect.com
- Thousand Oaks, CA  
+1 805 267 0100  
info.thousandoaks@smithsinterconnectinc.com

## Europe

- Deggendorf, Germany  
+49 991 250 120  
info.de@smithsinterconnect.com
- Genova, Italy  
+39 0 10 60361  
info.it@smithsinterconnect.com
- Dundee, UK  
+44 1382 427 200  
info.dundee@smithsinterconnect.com
- Rouen, France  
+33 2 32 96 91 76  
info.fr@smithsinterconnect.com
- Elstree, UK  
+44 20 8236 2400  
info.uk@smithsinterconnect.com

## Asia

- Shanghai, China  
+86 21 3318 4650  
info.asia@smithsinterconnect.com
- Suzhou, China  
+86 512 6273 1188  
info.asia@smithsinterconnect.com
- Singapore  
+65 6846 1655  
info.asia@smithsinterconnect.com